

# Z-FLEX<sup>®</sup>

CHIMNEY & VENTING SOLUTIONS



## Price List

February 2024

Chimney Lining Systems & Direct Vent

1-800-654-5600 [www.z-flex.com](http://www.z-flex.com)

<b>Aluminum Chimney Liner Kits for Category I Gas Fired Heating Equipment and Gas Fireplaces</b>	
Aluminum 2-ply Chimney Liner Kits	1
Additional Length of Aluminum 2-ply Liner	2
Aluminum 2-ply liner Extension Kit	2
Aluminum Liner Connector	2
<b>Aluminum Chimney Liner Kits for Category I Gas Fired Heating Equipment and Gas Fireplaces</b>	
1-Ply Aluminum Duct	3
Fresh Air Hood	3
Fresh Air Kit for Pellet Stoves	3
<b>Insul-Liner pre-insulated Chimney Liner for Category 1 Heating Equipment &amp; Gas Fireplaces</b>	
Insul-Liner Kits	4
Additional Length of Insul-Liner	4
Insul-Liner Coupling	4
<b>Stainless Steel Chimney Liner Kits for Oil, Gas Fired Units, Pellet Stoves &amp; Wood Inserts</b>	
SS All Fuel Chimney Liner Insert Kits with Stove Adapters	5
<b>Solid Fuel Insert Kit</b>	6
<b>Pre-Insulated Solid Fuel Insert Kit</b>	6
<b>All Fuel Stainless Steel Kit .006" Stainless Steel Liner</b>	7
<b>All Fuel Stainless Steel Kit .005" Material</b>	8
<b>Solid Fuel Liner Kit .005" Material</b>	9
<b>Solid Fuel Liner Kit .006" Material</b>	10
Insulating Blanket with Wrap and Gear Clamps	11
<b>Smoothcore Kit</b>	12
Triple Lock Smoothcore All Fuels Chimney Liner	13
Flexible Stainless Steel Oval to Round Liner	13
Flexible Stainless Steel Full Oval Liner	13
Stainless Steel Oval Flat Flashing	13
Stainless Steel Oval Cap	13
Stainless Steel Flex Ready Oval Base Tee with Cap	14
Stainless Steel Flex Ready Oval Liner Coupling	14
Stainless Steel Flex Ready Oval to Round Adapter	14
Stainless Steel Road to Oval Adapter	14
Stainless Steel Self-drilling screws	15
Stainless Steel 4" Flex Ready Pellet Tee with 3" branch	15
<b>Flexible Stainless Steel Round Liner Category I Chimney Liner</b>	
SS 316Ti Category I Chimney Liner per foot	16
SS Chimney Flashing (16"x 16" base)	17
SS Z-Max Cap (18" x 18")	17
Z-Max Prestressed Flashing (13" x 13")	17
Z-Max Flat Flashing (13" x 13")	17
<b>SS Flexible Round Liner Category I Chimney Liner</b>	
Z-Max Rain Cap	18
Z-Max All Fuel Raincap	18
Z-Max Raincap Extension	18
SS Drip-less Connector	19
Lock 'N Go Tee	19
Z-Lok Tee	19

Z-Lok Stacking Tee	20
Z-Lok Tee Stacking Spacer	20
Z-Lok 22 inch Tee Branch	20
Stove Adapter only	21
Swivel Offset Flex Ready Adapter	21
Offset Adapter	22
<b>All Fuel Rigid Stainless Steel Liner</b>	
SS 304 Rigid Liner Pipe Lengths	23
SS 304 Fixed 45° Elbow	23
SS 304 Fixed 90° Elbow	24
SS Rigid Stacking Tee with Cap and removable Spout	24
SS Increaser	24
SS Reducer	25
SS Deluxe Rain Cap	25
Nose Cone	25
Direct Vent Cover Page	26
<b>Direct Vent Co-Linear Flexible Liner Kits</b>	27
Direct Vent Kit Vertical Extreme Weather Termination	28
Direct Vent Kit Horizontal Round Termination	28
Direct Vent Kit Horizontal Square Termination	29
Coaxial Flexible Extension Kit	29
Coaxial Flexible Coupling Kit	29
Coaxial Flexible Spacer Kit	29
Direct Vent Adapter DV 4/6.625 to Flex 4/7 Kit	30
Adapter DV 5/8 to Flex 5/8 Kit	30
Coaxial Flexible Support Kit	30
4" - 7" Thick Wall Thimble	30
6"-11" Thick Wall Thimble Extended	31
Siding Standoff	31
Fire Stop	31
Fire Stop/Insulation Shield & Insulation Collar Kit	31
Flashing 30 to 45 Deg. Pitched Roofs	32
Rigid Extension Pipe Kit	32
Sealant	32
<b>Warranty</b>	33
<b>Terms &amp; Conditions of Sale</b>	34

**Aluminum Chimney Liner Kits for  
Category I Gas Fired Heating  
Equipment**

**Aluminum 2-ply Chimney Liner Kits**

Dia	Lgth	Part ID	Each
3"	20'	2GACKIT0320	\$246.59
3"	25'	2GACKIT0325	\$253.65
3"	30'	2GACKIT0330	\$303.00
3"	35'	2GACKIT0335	\$331.17
3"	40'	2GACKIT0340	\$432.16
3"	45'	2GACKIT0345	\$458.02
3"	50'	2GACKIT0350	\$483.83
4"	20'	2GACKIT0420	\$246.59
4"	25'	2GACKIT0425	\$253.65
4"	30'	2GACKIT0430	\$303.00
4"	35'	2GACKIT0435	\$331.17
4"	40'	2GACKIT0440	\$486.21
4"	45'	2GACKIT0445	\$526.10
4"	50'	2GACKIT0450	\$570.74
5"	20'	2GACKIT0520	\$295.94
5"	25'	2GACKIT0525	\$307.68
5"	30'	2GACKIT0530	\$349.98
5"	35'	2GACKIT0535	\$373.46
5"	40'	2GACKIT0540	\$530.84
5"	45'	2GACKIT0545	\$591.86
5"	50'	2GACKIT0550	\$641.22
5.5"	20'	2GACKIT05.520	\$360.49
5.5"	25'	2GACKIT05.525	\$372.35
5.5"	30'	2GACKIT05.530	\$448.21
5.5"	35'	2GACKIT05.535	\$469.58
5.5"	40'	2GACKIT05.540	\$647.42
5.5"	45'	2GACKIT05.545	\$690.12
5.5"	50'	2GACKIT05.550	\$730.46
6"	20'	2GACKIT0620	\$338.24
6"	25'	2GACKIT0625	\$349.98
6"	30'	2GACKIT0630	\$427.48
6"	35'	2GACKIT0635	\$448.62
6"	40'	2GACKIT0640	\$655.29
6"	45'	2GACKIT0645	\$695.25
6"	50'	2GACKIT0650	\$737.50

Dia	Lgth	Part ID	Each
7"	20'	2GACKIT0720	\$507.51
7"	25'	2GACKIT0725	\$554.97
7"	30'	2GACKIT0730	\$647.42
7"	35'	2GACKIT0735	\$668.78
7"	40'	2GACKIT0740	\$858.50
7"	45'	2GACKIT0745	\$927.27
7"	50'	2GACKIT0750	\$993.72
8"	20'	2GACKIT0820	\$554.97
8"	25'	2GACKIT0825	\$571.56
8"	30'	2GACKIT0830	\$709.11
8"	35'	2GACKIT0835	\$730.46
8"	40'	2GACKIT0840	\$1,005.55
8"	45'	2GACKIT0845	\$1,074.33
8"	50'	2GACKIT0850	\$1,143.09
9"	20'	2GACKIT0920	\$661.06
9"	25'	2GACKIT0925	\$747.72
9"	30'	2GACKIT0930	\$833.24
9"	35'	2GACKIT0935	\$914.61
9"	40'	2GACKIT0940	\$1,137.40
9"	45'	2GACKIT0945	\$1,189.19
9"	50'	2GACKIT0950	\$1,256.92
10"	20'	2GACKIT1020	\$619.00
10"	25'	2GACKIT1025	\$702.00
10"	30'	2GACKIT1030	\$896.48
10"	35'	2GACKIT1035	\$1,029.27
10"	40'	2GACKIT1040	\$1,283.03
10"	45'	2GACKIT1045	\$1,332.80
10"	50'	2GACKIT1050	\$1,377.88

**Order No: 2GACKIT (dia/lgth)**

**Kit includes:**

- 2-ply Aluminum Liner
- Chimney Flashing
- Bird Proof Rain Cap
- Mortar Collar, 3 Screws

**NOTE:** 5.5 inch Kits includes 5.5 inch to 6 inch adapter.



## Aluminum Chimney Liner Kits for Category I Gas Fired Heating Equipment and Gas Fireplaces

### Additional Length of Aluminum 2-Ply Liner

*Available in 5 ft increments only, up to 50 ft.*

Dia.	Part ID	List/FT
3"	2GAXXX03	\$8.00
4"	2GAXXX04	\$8.73
5"	2GAXXX05	\$10.86
5.5"	2GAXXX05.5	\$11.94
6"	2GAXXX06	\$13.05
7"	2GAXXX07	\$15.24
8"	2GAXXX08	\$17.39
9"	2GAXXX09	\$17.94
10"	2GAXXX10	\$21.15

Order No: 2GAXXX \_ \_ \_ \_ (dia lgth)



### Aluminum 2-ply Liner Extension Kit

*Kit includes: 10 feet 2 Ply Liner, 1 coupling & 2 clamps*

Dia.	Part ID	List/EA
3"	2GAEXT0310	\$95.61
4"	2GAEXT0410	\$102.47
5"	2GAEXT0510	\$122.98
5.5"	2GAEXT05.510	\$133.54
6"	2GAEXT0610	\$143.90
7"	2GAEXT0710	\$164.62
8"	2GAEXT0810	\$184.70
9"	2GAEXT0910	\$224.09
10"	2GAEXT1010	\$234.48

Order No: 2GAEXT \_ \_ \_ \_ (dia lgth)



### Aluminum Liner Connector

*To attach two lengths of aluminum liner.*

Dia.	Part ID	List/EA
3"	2CNNTRG03	\$13.32
4"	2CNNTRG04	\$14.18
5"	2CNNTRG05	\$15.17
5.5"	2CNNTRG05.5	\$16.63
6"	2CNNTRG06	\$18.29
7"	2CNNTRG07	\$19.08
8"	2CNNTRG08	\$21.09
9"	2CNNTRG09	\$26.15
10"	2CNNTRG10	\$29.40

Order No: 2CNNTRG \_ \_ (dia)



## Aluminum Chimney Liner Kits for Category I Gas Fired Heating Equipment and Gas Fireplaces

### 1 Ply Aluminum Duct

*Note: To be used in fresh air intake only.  
Not to be used as a chimney liner.  
See gas liner section. Available in 5 foot  
increments up to 50 foot length.*

Dia.	Part ID	List/FT
2"	1TLXXXX02	\$3.55
3"	1TLXXXX03	\$2.67
4"	1TLXXXX04	\$3.38
5"	1TLXXXX05	\$3.91
6"	1TLXXXX06	\$4.64

**Order No: 1TLXXXX \_ \_ \_ \_ (dia lgth)**



### Fresh Air Hood

Dia.	Part ID	List/EA
2"	2FAIGAL02	\$32.56
3"	2FAIGAL03	\$34.36
4"	2FAIGAL04	\$35.35



### Fresh Air Kit for Pellet Stoves

Kit includes:  
1 - 2" x 5' Aluminum 1 ply duct  
1 - 2" intake hood w/screen  
2 - 2" gear clamps

Dia	Part ID	Each
2"	2FAKIT0205	\$55.93

**Order No: 2FAKIT0205**



## Insul-Liner™ pre-insulated Chimney Liner for Category I Heating Equipment & Gas Fireplaces

### INSUL-LINER™ another "simple solution"

The National Fuel Gas Code (NFPA 54, ANSI Z223.1) recommends, but does not require that in certain situations liners be insulated.

Best practice, use an insulated liner in exterior chimneys or when a brick chimney has no clay liner.

The insulation will help keep the flue gases warm and prevent condensation.

Also, refer to the equipment manufacturer's instructions for their recommendations.

### INSUL-LINER™

- Takes the guess work out of insulating.
- No wrapping - liner is insulated at the factory.
- Simply remove from the box and install.
- Save installation time.

### Insul-Liner™ Kit 25' and 35' kit

Kit includes:     • Insulated Aluminum Liner, Chimney Flashing  
                          • Bird Proof Rain Cap, Mortar Collar, 3 screws



Dia.	Lgth	Part ID	Each
3"	25ft	2GIAKXX0325	\$723.40
4"	25ft	2GIAKXX0425	\$881.48
5"	25ft	2GIAKXX0525	\$1,004.46
6"	25ft	2GIAKXX0625	\$1,205.35
7"	25ft	2GIAKXX0725	\$1,376.63
8"	25ft	2GIAKXX0825	\$1,559.83
3"	35ft	2GIAKXX0335	\$1,012.76
4"	35ft	2GIAKXX0435	\$1,234.07
5"	35ft	2GIAKXX0535	\$1,406.24
6"	35ft	2GIAKXX0635	\$1,687.49
7"	35ft	2GIAKXX0735	\$1,927.29
8"	35ft	2GIAKXX0835	\$2,183.76

Order No: 2GIAKXX \_ \_ \_ \_ (dia/lgth)

### Additional Length™ Insul-Liner

Available up to 35 foot length.

Dia.	Part ID	Per FT
3"	2INSGAC03	\$19.16
4"	2INSGAC04	\$23.07
5"	2INSGAC05	\$28.23
6"	2INSGAC06	\$33.57
7"	2INSGAC07	\$38.77
8"	2INSGAC08	\$43.45

Order No: 2INSGAC \_ \_ \_ \_ (dia lgth)



### Insul-Liner™ Coupling

Used to join 2 pieces of Insul-Liner together

Dia.	Part ID	Each
3"	2IVUCXX03	\$33.66
4"	2IVUCXX04	\$34.38
5"	2IVUCXX05	\$34.74
6"	2IVUCXX06	\$35.30
7"	2IVUCXX07	\$37.57
8"	2IVUCXX08	\$39.68

Order No: 2IVUCXX \_ \_ (dia)

Pricing subject to change without notice



**All Fuel SS Insert Kit with Stove Adapter .005 Material**

Kit includes: Stainless Steel Liner, Z-Max<sup>®</sup> Rain Cap, Chimney Flashing, Stove Adapter

Dia	Lgth	Part ID	Each
3"	25'	2OILKTX0325I	\$619.83
3"	30'	2OILKTX0330I	\$729.31
3"	35'	2OILKTX0335I	\$838.80
3"	40'	2OILKTX0340I	\$948.13
3"	45'	2OILKTX0345I	\$1,056.90
3"	50'	2OILKTX0350I	\$1,167.30
4"	25'	2OILKTX0425I	\$812.10
4"	30'	2OILKTX0430I	\$952.84
4"	35'	2OILKTX0435I	\$1,097.23
4"	40'	2OILKTX0440I	\$1,242.90
4"	45'	2OILKTX0445I	\$1,388.67
4"	50'	2OILKTX0450I	\$1,533.74
5"	25'	2OILKTX0525I	\$1,021.55
5"	30'	2OILKTX0530I	\$1,299.47
5"	35'	2OILKTX0535I	\$1,396.82
5"	40'	2OILKTX0540I	\$1,583.67
5"	45'	2OILKTX0545I	\$1,772.31
5"	50'	2OILKTX0550I	\$1,957.86
5.5"	25'	2OILKTX05.525I	\$1,134.33
5.5"	30'	2OILKTX05.530I	\$1,346.95
5.5"	35'	2OILKTX05.535I	\$1,562.20
5.5"	40'	2OILKTX05.540I	\$1,767.40
5.5"	45'	2OILKTX05.545I	\$1,988.94
5.5"	50'	2OILKTX05.550I	\$2,201.98
6"	25'	2OILKTX0625I	\$1,157.52
6"	30'	2OILKTX0630I	\$1,369.16
6"	35'	2OILKTX0635I	\$1,584.42
6"	40'	2OILKTX0640I	\$1,789.62
6"	45'	2OILKTX0645I	\$2,011.16
6"	50'	2OILKTX0650I	\$2,224.19

Order No: 2OILKTX \_ \_ \_ \_ (dia/lgth)

Dia	Lgth	Part ID	Each
7"	25'	2OILKTX0725I	\$1,351.31
7"	30'	2OILKTX0730I	\$1,601.11
7"	35'	2OILKTX0735I	\$1,849.11
7"	40'	2OILKTX0740I	\$2,100.39
7"	45'	2OILKTX0745I	\$2,350.56
7"	50'	2OILKTX0750I	\$2,598.96
8"	25'	2OILKTX0825I	\$1,485.99
8"	30'	2OILKTX0830I	\$1,761.21
8"	35'	2OILKTX0835I	\$2,036.21
8"	40'	2OILKTX0840I	\$2,309.56
8"	45'	2OILKTX0845I	\$2,586.21
8"	50'	2OILKTX0850I	\$2,863.69

Order No: 2OILKTX \_ \_ \_ \_ (dia/lgth)





**Solid Fuel Insert Kit .005 Material**

New high flow rain cap resist creosote build up

Kit includes: Stainless Steel Liner, Z-Max<sup>®</sup> All Fuel Rain Cap, Prestressed 13 x 13 Flashing, Stove Connector

Dia	Lgth	Part ID	Each
3"	25'	2ZFSFIKIT0325	\$663.21
3"	30'	2ZFSFIKIT0330	\$780.36
3"	35'	2ZFSFIKIT0335	\$897.52
3"	40'	2ZFSFIKIT0340	\$1,014.50
3"	45'	2ZFSFIKIT0345	\$1,130.88
3"	50'	2ZFSFIKIT0350	\$1,249.01
4"	25'	2ZFSFIKIT0425	\$868.95
4"	30'	2ZFSFIKIT0430	\$1,019.54
4"	35'	2ZFSFIKIT0435	\$1,174.04
4"	40'	2ZFSFIKIT0440	\$1,329.90
4"	45'	2ZFSFIKIT0445	\$1,485.87
4"	50'	2ZFSFIKIT0450	\$1,641.10
5"	25'	2ZFSFIKIT0525	\$1,093.05
5"	30'	2ZFSFIKIT0530	\$1,390.43
5"	35'	2ZFSFIKIT0535	\$1,494.59
5"	40'	2ZFSFIKIT0540	\$1,694.53
5"	45'	2ZFSFIKIT0545	\$1,896.37
5"	50'	2ZFSFIKIT0550	\$2,094.91
5.5"	25'	2ZFSFIKIT05.525	\$1,213.73
5.5"	30'	2ZFSFIKIT05.530	\$1,441.24
5.5"	35'	2ZFSFIKIT05.535	\$1,671.55
5.5"	40'	2ZFSFIKIT05.540	\$1,891.12
5.5"	45'	2ZFSFIKIT05.545	\$2,128.17
5.5"	50'	2ZFSFIKIT05.550	\$2,356.11
6"	25'	2ZFSFIKIT0625	\$1,238.55
6"	30'	2ZFSFIKIT0630	\$1,465.00
6"	35'	2ZFSFIKIT0635	\$1,695.33
6"	40'	2ZFSFIKIT0640	\$1,914.89
6"	45'	2ZFSFIKIT0645	\$2,151.94
6"	50'	2ZFSFIKIT0650	\$2,379.89

Order No: 2ZFSFIKIT \_ \_ \_ \_ (dia/lgth)

Dia	Lgth	Part ID	Each
7"	25'	2ZFSFIKIT0725	\$1,445.90
7"	30'	2ZFSFIKIT0730	\$1,713.19
7"	35'	2ZFSFIKIT0735	\$1,978.55
7"	40'	2ZFSFIKIT0740	\$2,247.42
7"	45'	2ZFSFIKIT0745	\$2,515.10
7"	50'	2ZFSFIKIT0750	\$2,780.89
8"	25'	2ZFSFIKIT0825	\$1,590.01
8"	30'	2ZFSFIKIT0830	\$1,884.49
8"	35'	2ZFSFIKIT0835	\$2,178.75
8"	40'	2ZFSFIKIT0840	\$2,471.23
8"	45'	2ZFSFIKIT0845	\$2,767.25
8"	50'	2ZFSFIKIT0850	\$3,064.14

Order No: 2ZFSFIKIT \_ \_ \_ \_ (dia/lgth)



**NEW!**  
high flow all  
fuel rain cap  
resists creosote

**Pre-Insulated Solid Fuel Insert Kits**

Dia	Lgth	Part ID	Each
5.5	25	2ZFSFIKIT05.525PI	\$2,500.12
5.5	35	2ZFSFIKIT05.535PI	\$3,278.15
6	25	2ZFSFIKIT0625PI	\$2,562.57
6	35	2ZFSFIKIT0635PI	\$3,353.32
8	25	2ZFSFIKIT0825PI	\$3,936.04
8	35	2ZFSFIKIT0835PI	\$5,464.98



**Solid Fuel Insert Kit .006"Stainless Steel Liner**

New high flow rain cap resist creosote build up

Kit includes: .006" Stainless Steel Liner, Z-Max® All Fuel Rain Cap, Prestressed 13 x 13 Flashing, Stove Connector

Dia	Lgth	Part ID	Each
3"	25'	2ZFSFIKIT0325X	\$795.86
3"	30'	2ZFSFIKIT0330	\$936.43
3"	35'	2ZFSFIKIT0335X	\$1,077.02
3"	40'	2ZFSFIKIT0340X	\$1,217.40
3"	45'	2ZFSFIKIT0345X	\$1,357.06
3"	50'	2ZFSFIKIT0350X	\$1,498.81
4"	25'	2ZFSFIKIT0425X	\$1,042.74
4"	30'	2ZFSFIKIT0430X	\$1,223.45
4"	35'	2ZFSFIKIT0435X	\$1,408.84
4"	40'	2ZFSFIKIT0440X	\$1,595.88
4"	45'	2ZFSFIKIT0445X	\$1,783.05
4"	50'	2ZFSFIKIT0450X	\$1,969.32
5"	25'	2ZFSFIKIT0525X	\$1,311.66
5"	30'	2ZFSFIKIT0530X	\$1,668.52
5"	35'	2ZFSFIKIT0535X	\$1,793.51
5"	40'	2ZFSFIKIT0540X	\$2,033.44
5"	45'	2ZFSFIKIT0545	\$2,275.64
5"	50'	2ZFSFIKIT0550X	\$2,513.89
5.5"	25'	2ZFSFIKIT05.525X	\$1,456.47
5.5"	30'	2ZFSFIKIT05.530X	\$1,729.48
5.5"	35'	2ZFSFIKIT05.535X	\$2,005.87
5.5"	40'	2ZFSFIKIT05.540X	\$2,269.34
5.5"	45'	2ZFSFIKIT05.545X	\$2,553.80
5.5"	50'	2ZFSFIKIT05.550X	\$2,827.34
6"	25'	2ZFSFIKIT0625X	\$1,486.26
6"	30'	2ZFSFIKIT0630X	\$1,758.00
6"	35'	2ZFSFIKIT0635X	\$2,034.39
6"	40'	2ZFSFIKIT0640X	\$2,297.87
6"	45'	2ZFSFIKIT0645X	\$2,582.33
6"	50'	2ZFSFIKIT0650X	\$2,855.87

Order No: 2ZFSFIKIT \_ \_ \_ \_ (dia/lgth)

Dia	Lgth	Part ID	Each
7"	25'	2ZFSFIKIT0725X	\$1,735.08
7"	30'	2ZFSFIKIT0730X	\$2,055.83
7"	35'	2ZFSFIKIT0735X	\$2,374.26
7"	40'	2ZFSFIKIT0740X	\$2,696.90
7"	45'	2ZFSFIKIT0745X	\$3,018.12
7"	50'	2ZFSFIKIT0750X	\$3,337.06
8"	25'	2ZFSFIKIT0825X	\$1,908.01
8"	30'	2ZFSFIKIT0830X	\$2,261.39
8"	35'	2ZFSFIKIT0835X	\$2,614.50
8"	40'	2ZFSFIKIT0840X	\$2,965.47
8"	45'	2ZFSFIKIT0845X	\$3,320.70
8"	50'	2ZFSFIKIT0850X	\$3,676.97

Order No: 2ZFSFIKIT \_ \_ \_ \_ (dia/lgth)



**NEW!**  
high flow all  
fuel rain cap  
resists  
creosote  
buildup

## All Fuel Stainless Steel Liner Kits for Free Standing Wood Stoves

### All Fuel Stainless Steel Kit .005 Material

Dia	Lgth	Part ID	Each	Dia	Lgth	Part ID	Each
3"	25'	2ZFLKIT0325	\$812.08	7"	25'	2ZFLKIT0725	\$1,366.39
3"	30'	2ZFLKIT0330	\$923.58	7"	30'	2ZFLKIT0730	\$1,611.32
3"	35'	2ZFLKIT0335	\$1,034.71	7"	35'	2ZFLKIT0735	\$1,855.50
3"	40'	2ZFLKIT0340	\$1,146.25	7"	40'	2ZFLKIT0740	\$2,099.01
3"	45'	2ZFLKIT0345	\$1,258.24	7"	45'	2ZFLKIT0745	\$2,346.06
3"	50'	2ZFLKIT0350	\$1,369.10	7"	50'	2ZFLKIT0750	\$2,589.54
4"	25'	2ZFLKIT0425	\$864.64	8"	25'	2ZFLKIT0825	\$1,500.04
4"	30'	2ZFLKIT0430	\$1,012.58	8"	30'	2ZFLKIT0830	\$1,770.20
4"	35'	2ZFLKIT0435	\$1,160.85	8"	35'	2ZFLKIT0835	\$2,040.35
4"	40'	2ZFLKIT0440	\$1,309.33	8"	40'	2ZFLKIT0840	\$2,308.73
4"	45'	2ZFLKIT0445	\$1,457.04	8"	45'	2ZFLKIT0845	\$2,578.88
4"	50'	2ZFLKIT0450	\$1,604.63	8"	50'	2ZFLKIT0850	\$2,849.02
5"	25'	2ZFLKIT0525	\$1,046.81	9"	25'	2ZFLKIT0925	\$1,821.74
5"	30'	2ZFLKIT0530	\$1,231.00	9"	30'	2ZFLKIT0930	\$2,079.48
5"	35'	2ZFLKIT0535	\$1,414.76	9"	35'	2ZFLKIT0935	\$2,506.00
5"	40'	2ZFLKIT0540	\$1,598.69	9"	40'	2ZFLKIT0940	\$2,900.57
5"	45'	2ZFLKIT0545	\$1,782.67	9"	45'	2ZFLKIT0945	\$3,216.96
5"	50'	2ZFLKIT0550	\$1,966.60	9"	50'	2ZFLKIT0950	\$3,428.43
5.5"	25'	2ZFLKIT05.525	\$1,156.22	10"	25'	2ZFLKIT1025	\$1,956.81
5.5"	30'	2ZFLKIT05.530	\$1,361.21	10"	30'	2ZFLKIT1030	\$2,315.85
5.5"	35'	2ZFLKIT05.535	\$1,565.84	10"	35'	2ZFLKIT1035	\$2,674.86
5.5"	40'	2ZFLKIT05.540	\$1,771.39	10"	40'	2ZFLKIT1040	\$3,030.32
5.5"	45'	2ZFLKIT05.545	\$1,975.16	10"	45'	2ZFLKIT1045	\$3,387.56
5.5"	50'	2ZFLKIT05.550	\$2,180.70	10"	50'	2ZFLKIT1050	\$3,744.80
6"	25'	2ZFLKIT0625	\$1,179.77				
6"	30'	2ZFLKIT0630	\$1,388.99				
6"	35'	2ZFLKIT0635	\$1,597.79				
6"	40'	2ZFLKIT0640	\$1,807.53				
6"	45'	2ZFLKIT0645	\$2,016.17				
6"	50'	2ZFLKIT0650	\$2,225.18				

### Z-Max Cap &

Alloy 316Ti

**Kit includes:**

Liner

Z-Max Cap & Flashing

Z-Lok Flex Tee

Patented airtight triple lock construction is tested and listed by UL. Triple Lock® Joint accepted by industry as the strongest joint system available.

Order No: 2ZFLKIT \_ \_ \_ \_ (dia/lgth)

**Kit must be insulated for wood burning applications.**



**Solid Fuel Liner Kit .005 Material**

New High Flow All Fuel raincap resists creosote buildup

Dia	Lgth	Part ID	Each
3"	25'	2ZFSFKIT0325	\$868.93
3"	30'	2ZFSFKIT0330	\$988.23
3"	35'	2ZFSFKIT0335	\$1,107.14
3"	40'	2ZFSFKIT0340	\$1,226.49
3"	45'	2ZFSFKIT0345	\$1,346.31
3"	50'	2ZFSFKIT0350	\$1,464.93
4"	25'	2ZFSFKIT0425	\$925.17
4"	30'	2ZFSFKIT0430	\$1,083.46
4"	35'	2ZFSFKIT0435	\$1,242.11
4"	40'	2ZFSFKIT0440	\$1,400.98
4"	45'	2ZFSFKIT0445	\$1,559.04
4"	50'	2ZFSFKIT0450	\$1,716.96
5"	25'	2ZFSFKIT0525	\$1,120.08
5"	30'	2ZFSFKIT0530	\$1,317.17
5"	35'	2ZFSFKIT0535	\$1,513.79
5"	40'	2ZFSFKIT0540	\$1,710.60
5"	45'	2ZFSFKIT0545	\$1,907.46
5"	50'	2ZFSFKIT0550	\$2,104.26
5.5"	25'	2ZFSFKIT05.525	\$1,237.15
5.5"	30'	2ZFSFKIT05.530	\$1,456.49
5.5"	35'	2ZFSFKIT05.535	\$1,675.45
5.5"	40'	2ZFSFKIT05.540	\$1,895.39
5.5"	45'	2ZFSFKIT05.545	\$2,113.42
5.5"	50'	2ZFSFKIT05.550	\$2,333.35
6"	25'	2ZFSFKIT0625	\$1,262.35
6"	30'	2ZFSFKIT0630	\$1,486.22
6"	35'	2ZFSFKIT0635	\$1,709.63
6"	40'	2ZFSFKIT0640	\$1,934.06
6"	45'	2ZFSFKIT0645	\$2,157.30
6"	50'	2ZFSFKIT0650	\$2,380.94

Dia	Lgth	Part ID	Each
7"	25'	2ZFSFKIT0725	\$1,462.03
7"	30'	2ZFSFKIT0730	\$1,724.11
7"	35'	2ZFSFKIT0735	\$1,985.38
7"	40'	2ZFSFKIT0740	\$2,245.94
7"	45'	2ZFSFKIT0745	\$2,510.28
7"	50'	2ZFSFKIT0750	\$2,770.81
8"	25'	2ZFSFKIT0825	\$1,605.04
8"	30'	2ZFSFKIT0830	\$1,894.11
8"	35'	2ZFSFKIT0835	\$2,183.17
8"	40'	2ZFSFKIT0840	\$2,470.34
8"	45'	2ZFSFKIT0845	\$2,759.41
8"	50'	2ZFSFKIT0850	\$3,048.45
9"	25'	2ZFSFKIT0925	\$1,949.26
9"	30'	2ZFSFKIT0930	\$2,225.05
9"	35'	2ZFSFKIT0935	\$2,681.42
9"	40'	2ZFSFKIT0940	\$3,103.61
9"	45'	2ZFSFKIT0945	\$3,442.15
9"	50'	2ZFSFKIT0950	\$3,668.42
10"	25'	2ZFSFKIT1025	\$2,093.79
10"	30'	2ZFSFKIT1030	\$2,477.96
10"	35'	2ZFSFKIT1035	\$2,862.11
10"	40'	2ZFSFKIT1040	\$3,242.44
10"	45'	2ZFSFKIT1045	\$3,624.69
10"	50'	2ZFSFKIT1050	\$4,006.94

Z-Max Cap & Flashing  
Alloy 316Ti  
Kit includes: Liner  
Z-Max All Fuel Cap  
Z-Lok Flex Tee  
Pre-stressed 13 x 13  
Flashing  
Patented airtight  
Triple Lock<sup>®</sup>  
construction is tested  
and listed by UL.  
Triple Lock<sup>®</sup> Joint  
accepted by industry  
as the strongest joint

Order No: 2ZFSFKIT \_\_\_\_ (dia/lgth)

**Kit must be insulated for wood burning applications.**



**Solid Fuel Liner Kit .006 Material**

**Solid Fuel Liner Kits  
for Free Standing Wood Stoves**

New High Flow All Fuel raincap resists creosote buildup  
Alloy 316Ti

Kit includes:

.006" Stainless Steel Liner

Z-Max All Fuel Cap

Z-Lok Flex Tee

Pre-stressed 13 x 13 Flashing

Patented airtight Triple Lock® construction  
is tested and listed by UL

Triple Lock® Joint accepted by industry as the  
strongest joint system available.

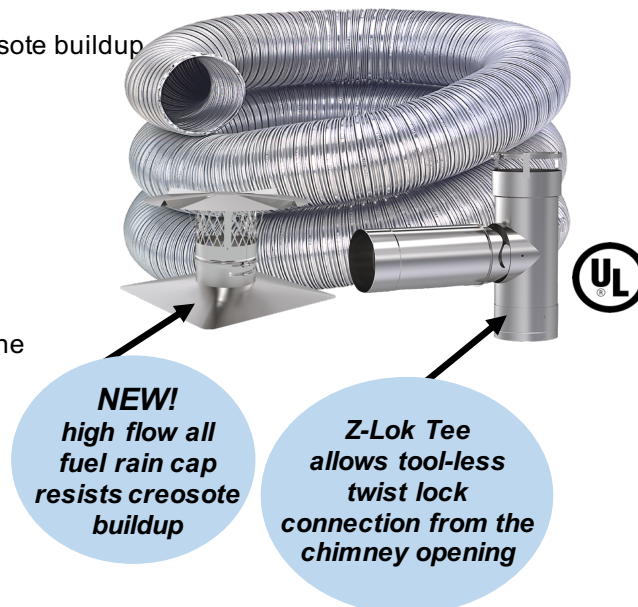

Dia	Lgth	Part ID	Each	Dia	Lgth	Part ID	Each
3"	25'	2ZFSFKIT0325X	\$1,042.71	7"	25'	2ZFSFKIT0725X	\$1,754.44
3"	30'	2ZFSFKIT0330X	\$1,185.88	7"	30'	2ZFSFKIT0730X	\$2,068.93
3"	35'	2ZFSFKIT0335X	\$1,328.57	7"	35'	2ZFSFKIT0735X	\$2,382.46
3"	40'	2ZFSFKIT0340X	\$1,471.79	7"	40'	2ZFSFKIT0740X	\$2,695.13
3"	45'	2ZFSFKIT0345X	\$1,615.58	7"	45'	2ZFSFKIT0745X	\$3,012.34
3"	50'	2ZFSFKIT0350X	\$1,757.92	7"	50'	2ZFSFKIT0750X	\$3,324.97
4"	25'	2ZFSFKIT0425X	\$1,110.20	8"	25'	2ZFSFKIT0825X	\$1,926.05
4"	30'	2ZFSFKIT0430X	\$1,300.15	8"	30'	2ZFSFKIT0830X	\$2,272.93
4"	35'	2ZFSFKIT0435X	\$1,490.53	8"	35'	2ZFSFKIT0835X	\$2,619.81
4"	40'	2ZFSFKIT0440X	\$1,681.18	8"	40'	2ZFSFKIT0840X	\$2,964.41
4"	45'	2ZFSFKIT0445X	\$1,870.84	8"	45'	2ZFSFKIT0845X	\$3,311.29
4"	50'	2ZFSFKIT0450X	\$2,060.35	8"	50'	2ZFSFKIT0850X	\$3,658.14
5"	25'	2ZFSFKIT0525X	\$1,344.10	9"	25'	2ZFSFKIT0925X	\$2,339.11
5"	30'	2ZFSFKIT0530X	\$1,580.60	9"	30'	2ZFSFKIT0930X	\$2,670.06
5"	35'	2ZFSFKIT0535X	\$1,816.55	9"	35'	2ZFSFKIT0935X	\$3,217.71
5"	40'	2ZFSFKIT0540X	\$2,052.72	9"	40'	2ZFSFKIT0940X	\$3,724.34
5"	45'	2ZFSFKIT0545X	\$2,288.95	9"	45'	2ZFSFKIT0945X	\$4,130.57
5"	50'	2ZFSFKIT0550X	\$2,525.11	9"	50'	2ZFSFKIT0950X	\$4,402.10
5.5"	25'	2ZFSFKIT05.525X	\$1,484.58	10"	25'	2ZFSFKIT1025X	\$2,512.55
5.5"	30'	2ZFSFKIT05.530X	\$1,747.79	10"	30'	2ZFSFKIT1030X	\$2,973.55
5.5"	35'	2ZFSFKIT05.535X	\$2,010.54	10"	35'	2ZFSFKIT1035X	\$3,434.53
5.5"	40'	2ZFSFKIT05.540X	\$2,274.47	10"	40'	2ZFSFKIT1040X	\$3,890.93
5.5"	45'	2ZFSFKIT05.545X	\$2,536.10	10"	45'	2ZFSFKIT1045X	\$4,349.63
5.5"	50'	2ZFSFKIT05.550X	\$2,800.02	10"	50'	2ZFSFKIT1050X	\$4,808.33
6"	25'	2ZFSFKIT0625X	\$1,514.82				
6"	30'	2ZFSFKIT0630X	\$1,783.47				
6"	35'	2ZFSFKIT0635X	\$2,051.56				
6"	40'	2ZFSFKIT0640X	\$2,320.87				
6"	45'	2ZFSFKIT0645X	\$2,588.76				
6"	50'	2ZFSFKIT0650X	\$2,857.13				

Order No: 2ZFSFKIT \_ \_ \_ \_ (dia/lgth)

**Kit must be insulated for wood burning applications.**

## All Fuel Stainless Steel Liner Kits for Free Standing Wood Stoves

### Insulating Blanket with Wrap and Gear Clamps

Dia	Part ID	Per FT
4"	2INSKIT04 _ _	\$31.35
5"	2INSKIT05 _ _	\$36.89
6"	2INSKIT06 _ _	\$46.11
7"	2INSKIT07 _ _	\$49.81
8"	2INSKIT08 _ _	\$53.50
10"	2INSKIT10 _ _	\$57.18

**Order No: 2INSKIT \_ \_ \_ \_ (dia/lgth)**



Available in 5 ft, 10 ft and 25 ft lengths  
3 clamps included for every 5 foot  
of blanket purchased.

**Mandatory for wood burning applications.**

## Smoothcore Stainless Steel Chimney Liner Kits for Oil, Gas & Pellet Stoves

### Smoothcore Kit

Kit includes: Stainless Steel Liner, Z-Lok<sup>®</sup>. Tee, Z-Max<sup>®</sup> Chimney Flashing, Z-Max<sup>®</sup> Rain Cap

Dia	Lgth	Part ID	Each
3"	25'	2ZFSCKIT0325	\$1,015.10
3"	30'	2ZFSCKIT0330	\$1,154.44
3"	35'	2ZFSCKIT0335	\$1,293.36
4"	25'	2ZFSCKIT0425	\$1,080.82
4"	30'	2ZFSCKIT0430	\$1,265.71
4"	35'	2ZFSCKIT0435	\$1,451.09
5"	25'	2ZFSCKIT0525	\$1,308.54
5"	30'	2ZFSCKIT0530	\$1,538.71
5"	35'	2ZFSCKIT0535	\$1,768.42
6"	25'	2ZFSCKIT0625	\$1,474.71
6"	30'	2ZFSCKIT0630	\$1,736.22
6"	35'	2ZFSCKIT0635	\$1,997.26
7"	25'	2ZFSCKIT0725	\$1,707.97
7"	30'	2ZFSCKIT0730	\$2,014.16
7"	35'	2ZFSCKIT0735	\$2,319.39
8"	25'	2ZFSCKIT0825	\$1,875.07
8"	30'	2ZFSCKIT0830	\$2,212.75
8"	35'	2ZFSCKIT0835	\$2,550.46



Proprietary 316Ti Plus Titanium stainless steel ensures indefinite service life and increased safety, in containing creosote fires. cUL tested and listed by UL to UL1777 and ULC S635.

Order No: 2ZFSCKIT\_ \_ \_ \_ (dia/lgth)

Smoothcore eliminates the turbulence inherent with corrugated liners, improving draft. Resists corrosive attack by not impeding the flow of condensate down the liner, therefore, less opportunity for soot to accumulate. Patented Triple-Lock<sup>®</sup> design won't pull apart during installation, or under extreme heat. conditions.

### Triple Lock<sup>®</sup> Smoothcore All Fuels Chimney Liner

Dia	Part ID	Per FT
3"	2ZLSCXX03 _ _	\$28.63
4"	2ZLSCXX04 _ _	\$37.93
5"	2ZLSCXX05 _ _	\$49.37
6"	2ZLSCXX06 _ _	\$55.98
7"	2ZLSCXX07 _ _	\$65.06
8"	2ZLSCXX08 _ _	\$71.72

Order No: 2ZLSCXX\_ \_ \_ \_ (dia/lgth)

Additional lengths 5 Ft to 20Ft. - 5Ft increments.



**Flexible Stainless Steel Oval to Round Liner**

Dia	Oval Dimension	Per FT
6"	6 IN Oval to Round Flexible Liner - 4"x7-1/2"	\$55.41
7"	7 IN Oval to Round Flexible Liner - 4"x9"	\$64.02
8"	8 IN Oval to Round Flexible Liner - 4-1/2"x10-1/2"	\$70.62
10"	10 IN Oval to Round Flexible Liner - 5"x14"	\$88.29

**Order No: 2ZLSSOR** \_ \_ \_ \_ (dia lgth)

Available in 5ft sections (1ft Round, 4ft Oval)

**Note:** To be used in areas that are restrictive in one dimension.



**Flexible Stainless Steel Full Oval Liner**

Dia	Oval Dimension	Per FT
6"	6 IN Oval Flexible Liner - 4"x7-1/2"	\$55.41
7"	7 IN Oval Flexible Liner - 4"x9"	\$64.02
8"	8 IN Oval Flexible Liner - 4-1/2"x10-1/2"	\$70.62
10"	10 IN Oval Flexible Liner - 5"x14"	\$88.29

**Order No: 2ZLSSOX** \_ \_ \_ \_ (dia lgth)

Available in 5ft & 10ft Sections



**Stainless Steel Oval Flat Flashing**

Dia	Oval Dimension	Each
6"	SS Oval Flat Flashing 6 IN - 4"x7-1/2"	\$130.94
7"	SS Oval Flat Flashing 7 IN - 4"x9"	\$141.49

**Order No: 2ZSCO18** (dia)



**Stainless Steel Oval Cap**

Dia	Oval Dimension	Each
6"	Oval Cap SS 6 IN - 4"x7-1/2"	\$171.15
7"	Oval Cap SS 7 IN - 4"x9"	\$176.21

**Order No: 2ZMRCV** (dia)





**Oval Flex Ready  
All Fuel Stainless Steel**

**Stainless Steel Flex Ready Oval Base Tee with Cap.**

Oval Flex ready w/round take off.

Dia	Oval Dimension	Each
6"	Flex Oval Base Tee /Cap 6 IN - 4"x7-1/2"	\$203.52
7"	Flex Oval Base Tee /Cap 7 IN - 4"x9"	\$214.83
8"	Flex Oval Base Tee /Cap 8 IN - 4-1/2"x10-1/2"	\$226.16
10"	Flex Oval Base Tee /Cap 10 IN - 5"x14"	\$237.45

**Order No: 2ZFOT \_\_ (dia)**



**Stainless Steel Flex Ready Oval Liner Coupling**

Flex ready - Used to connect 2 same size oval pipe.

Dia	Oval Dimension	Each
6"	Connector A Oval 6 IN - 4"x7-1/2"	\$88.70
7"	Connector A Oval 7 IN - 4"x9"	\$97.15
8"	Connector A Oval 8 IN - 4-1/2"x10-1/2"	\$105.58
10"	Connector A Oval 10 IN - 5"x14"	\$114.01

**Order No: 2CNTRA \_\_ OV**

Used to mate two pieces of oval liner together.

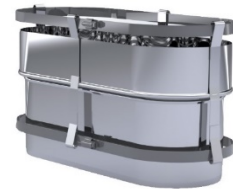

**Stainless Steel Flex Ready Oval to Round Adapter**

Dia	Oval Dimension	Each
6"	Oval to Round Flex Ready 6 IN - 4"x7-1/2"	\$107.98
7"	Oval to Round Flex Ready 7 IN - 4"x9"	\$123.48
8"	Oval to Round Flex ReDY 8 IN - 4-1/2"x10-1/2"	\$137.10
10"	Oval to Round Flex Ready 10 IN - 5"x14"	\$150.91

**Order No: 2ZRORAX (dia)**

Round end accepts Flex



**Stainless Steel Round to Oval Adapter**

Dia	Oval Dimension	Each
6"	Round to Oval 6 IN - 4"x7-1/2"	\$107.98
7"	Round to Oval 7 IN - 4"x9"	\$123.48
8"	Round to Oval 8 IN - 4-1/2"x10-1/2"	\$137.10
10"	Round to Oval 10 IN - 5"x14"	\$150.91

**Order No: 2ZRROAX (dia)**

Oval ends accepts flex



**SS Chimney Liner Kits for  
Oil, Gas & Pellet Stoves**

**Stainless Steel self-drilling screws**

Bag of 50 screws

Dia	Lgth	Part ID	Each
NA	NA	2SSSCREW	\$23.46

**Order No: 2SSSCREW**



**4" Flex Ready Pellet Tee  
with 3" branch**

Dia		Part ID	Each
4"		2ZPT43	\$119.10

**Order No: 2ZPT43**

**New Product!**

Connects Z-Flex to solid fuel inserts where space is minimal



## Flexible Stainless Steel Round Liner Category I Chimney Liner

**Patented airtight triple lock construction.**

Ideal for use with gas, oil, pellet and wood. (For use with coal, seewarranty).

Liner must be insulated with a Z-Flex® Insulationblanket for wood burning installation

The patented "T Lock" construction is tested and listed by U.L. Triple Lock Joint accepted by industry as the strongest joint system. Z-Flex is easily installed in minimal time. Special high temperature and acid resistant stainless steel is exclusive to Z-Flex.



**.005 SS Alloy - 316Ti**

Dia	Part ID	Per FT
3"	2ZLSSXX03	\$22.85
4"	2ZLSSXX04	\$30.36
5"	2ZLSSXX05	\$39.52
5.5"	2ZLSSXX05.5	\$43.00
6"	2ZLSSXX06	\$44.90
7"	2ZLSSXX07	\$52.05
8"	2ZLSSXX08	\$57.39
9"	2ZLSSXX09	\$63.54
10"	2ZLSSXX10	\$76.08

Order No: 2ZLSSXX \_ \_ \_ \_ (dia/lgth)

- **Lightweight, easily handled, easily flexed**  
Available diameters: 3" through 10" diameter in 5 foot increments up to 50 foot lengths.  
*Prices for special sizes are available on request.*



**.006 SS Alloy - 316Ti**

Dia	Part ID	Per FT
3"	2ZLSS6X03 _ _	\$22.63
4"	2ZLSS6X04 _ _	\$35.37
5"	2ZLSS6X05 _ _	\$46.05
5.5"	2ZLSS6X05.5 _ _	\$50.10
6"	2ZLSS6X06 _ _	\$52.31
7"	2ZLSS6X07 _ _	\$60.64
8"	2ZLSS6X08 _ _	\$66.86
9"	2ZLSS6X09 _ _	\$74.03
10"	2ZLSS6X10 _ _	\$88.64

Order No: 2ZLSSXX \_ \_ \_ \_ (dia/lgth)

## Flexible Stainless Steel Round Liner Category I Chimney Liner

### Stainless Steel Chimney Flashing (16"x16" base)

Used to seal off the top of the Chimney after the installation is complete.

Dia	Part ID	Each
3"	2ZSCSXX03	
4"	2ZSCSXX04	\$88.83
5"	2ZSCSXX05	\$91.40
5.5"	2ZSCSXX05.5	\$92.33
6"	2ZSCSXX06	\$93.15
7"	2ZSCSXX07	\$93.81
8"	2ZSCSXX08	\$96.43
9"	2ZSCSXX09	\$97.72
10"	2ZSCSXX10	\$98.98

Order No: 2ZSCSXX \_\_ (dia)



### Z-Max Stainless Steel Flashing Flat (18" x 18" base)

Dia	Part ID	Each
3"	2ZSCS1803	\$104.53
4"	2ZSCS1804	\$106.63
5"	2ZSCS1805	\$109.67
5.5"	2ZSCS1805.5	\$110.83
6"	2ZSCS1806	\$111.83
7"	2ZSCS1807	\$120.07
8"	2ZSCS1808	\$126.11

Order No: 2ZSCS18 \_\_ (dia)

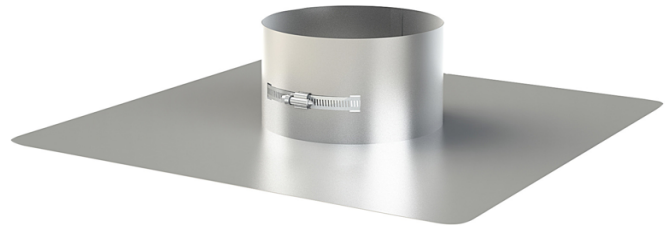

### Z-Max Prestressed Flashing (13"x 13" base)

Dia	Part ID	Each
3"	2AFCS03	\$88.83
4"	2AFCS04	\$88.83
5"	2AFCS05	\$91.41
5.5"	2AFCS05.5	\$92.33
6"	2AFCS06	\$93.15
7"	2AFCS07	\$108.66
8"	2AFCS08	\$124.18

Order No: 2AFCS \_\_ (dia)

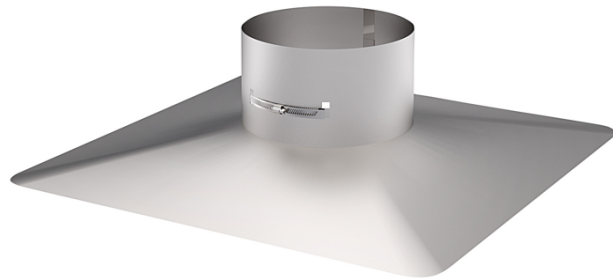

### Z-Max Flat Flashing (13"x 13" base)

Dia	Part ID	Each
3"	2ZSCS1303	\$86.33
4"	2ZSCS1304	\$88.82
5"	2ZSCS1305	\$91.39
5.5"	2ZSCS1305.5	\$92.33
6"	2ZSCS1306	\$93.15
7"	2ZSCS1307	\$93.81
8"	2ZSCS1308	\$96.44

Order No: 2ZSCS13 \_\_ (dia)

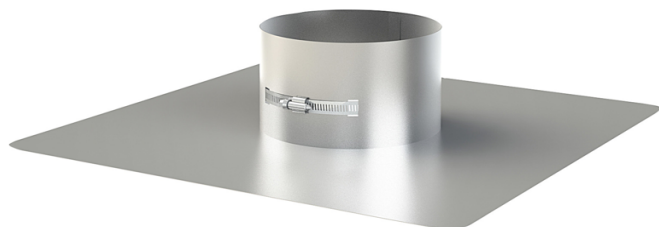

## Flexible Stainless Steel Round Liner Category I Chimney Liner

### Z-Max RainCap

Dia	Part ID	Each
3"	2ZMRCS03	\$89.32
4"	2ZMRCS04	\$119.12
5"	2ZMRCS05	\$131.81
5.5"	2ZMRCS05.5	\$139.47
6"	2ZMRCS06	\$144.65
7"	2ZMRCS07	\$168.75
8"	2ZMRCS08	\$192.89

Order No: 2ZMRCS \_\_ (dia)



### Z-Max All Fuel Raincap

Dia	Part ID	Each
3"	2ZMRCA03	\$166.15
4"	2ZMRCA04	\$221.55
5"	2ZMRCA05	\$245.14
5.5"	2ZMRCA05.5	\$259.40
6"	2ZMRCA06	\$269.07
7"	2ZMRCA07	\$313.88
8"	2ZMRCA08	\$358.77
10"	2ZMRCA10	\$410.03

Order No: 2ZMEXT \_\_ (dia)



### Z-Max Raincap Extension

18" Length Pipe used to extend Z-Max Raincap.

Dia	Part ID	Each
3"	2ZMEXT03	\$88.83
4"	2ZMEXT04	\$88.83
5"	2ZMEXT05	\$91.41
5.5"	2ZMEXT05.5	\$92.33
6"	2ZMEXT06	\$93.15
7"	2ZMEXT07	\$108.66
8"	2ZMEXT08	\$124.18

Order No: 2ZMEXT \_\_ (dia)



## Stainless Steel Drip-less Connector

Used to mate Z-Flex liner to liner, T-Section stove pipe or fireplace insert.

Dia	Part ID	Each
3"	2CNNTRC03	\$51.46
4"	2CNNTRC04	\$54.81
5"	2CNNTRC05	\$61.22
5.5"	2CNNTRC05.5	\$61.67
6"	2CNNTRC06	\$61.81
7"	2CNNTRC07	\$65.10
8"	2CNNTRC08	\$68.38
9"	2CNNTRC09	\$69.99
10"	2CNNTRC10	\$71.62

Order No: 2CNNTRC \_\_ (dia)



## Lock'N Go Tee

Dia	Part ID	Each
3"	2ZFTCB03	\$114.89
4"	2ZFTCB04	\$125.98
5"	2ZFTCB05	\$137.10
5.5"	2ZFTCB05.5	\$146.07
6"	2ZFTCB06	\$153.37
7"	2ZFTCB07	\$164.12
8"	2ZFTCB08	\$176.85
9"	2ZFTCB09	\$207.65
10"	2ZFTCB10	\$238.44

Order No: 2ZFTCB \_\_ (dia)



### Lock'N Go Tee -

Installs in half the time, compared to regular Tee with no special tools required.

Available in 3-inch through 24-inch diameters. Special 22" long branch available.

Refer to rigid tee for use with Rigid liner or when stacking tees together.

**NOTE: 3 Inch and 10 Inch nose spouts are not removal.**

## Z-Lok™ Tee

Dia	Part ID	Each
3"	2ZFTJ03	\$114.89
4"	2ZFTJ04	\$125.98
5"	2ZFTJ05	\$137.10
5.5"	2ZFTJ05.5	\$146.07
6"	2ZFTJ06	\$153.37
7"	2ZFTJ07	\$164.12
8"	2ZFTJ08	\$176.85
9"	2ZFTJ09	\$207.65
10"	2ZFTJ10	\$238.44

Order No: 2ZFTJ \_\_ (dia)



## Z-Lok Stacking Tee

Used for stacking Z-Lok tees together. Tee cap can be used vertically or horizontally.

Dia	Part ID	Each
2ZFTJS03	Z-LOK TEE STACKING 3IN X 10L BRANCH	\$114.89
2ZFTJS04	Z-LOK TEE STACKING 4IN X 10L BRANCH	\$125.98
2ZFTJS0S	Z-LOK TEE STACKING 5IN X 10L BRANCH	\$137.10
2ZFTJS0S.S	Z-LOK TEE STACKING 5.5IN X 10L BRANCH	\$153.37
2ZFTJS06	Z-LOK TEE STACKING 6IN X 10L BRANCH	\$153.37
2ZFTJS07	Z-LOK TEE STACKING 7IN X 10L BRANCH	\$163.35
2ZFTJS08	Z-LOK TEE STACKING 8IN X 10L BRANCH	\$176.85
2ZFTJS09	Z-LOK TEE STACKING 9IN X 10L BRANCH	\$192.23
2ZFTJS10	Z-LOK TEE STACKING 10IN X 10L BRANCH	\$247.61



## Z-Lok Tee Stacking Spacer

Used when there is going to be a space between stacking tees.

Dia	Part ID	Each
2ZFTJS041	Z-LOK TEE STACKING SPACER 4IN X 1FT	\$38.79
2ZFTJS051	Z-LOK TEE STACKING SPACER 5IN X 1FT	\$42.41
2ZFTJS0S.51	Z-LOK TEE STACKING SPACER 5.5IN X 1FT	\$44.22
2ZFTJS061	Z-LOK TEE STACKING SPACER 6IN X 1FT	\$46.01
2ZFTJS071	Z-LOK TEE STACKING SPACER 7IN X 1FT	\$51.46
2ZFTJS081	Z-LOK TEE STACKING SPACER 8IN X 1FT	\$74.81
2ZFTJS091	Z-LOK TEE STACKING SPACER 9IN X 1FT	\$86.94
2ZFTJS101	Z-LOK TEE STACKING SPACER 10IN X 1FT	\$99.07



## Z-Lok 22 inch Tee Branch

Used when a longer branch is needed. Branch is cuttable.

Dia	Part ID	Each
2ZFTJB03X	Z-LOK 3IN X 22L BRANCH	\$61.16
2ZFTJB04X	Z-LOK 4IN X 22L BRANCH	\$66.47
2ZFTJB05X	Z-LOK 5IN X 22L BRANCH	\$72.23
2ZFTJB05.5X	Z-LOK 5.5IN X 22L BRANCH	\$74.97
2ZFTJB06X	Z-LOK 6IN X 22L BRANCH	\$77.62
2ZFTJB07X	Z-LOK 7IN X 22L BRANCH	\$87.16
2ZFTJB08X	Z-LOK 8IN X 22L BRANCH	\$96.86
2ZFTJB09X	Z-LOK 9IN X 22L BRANCH	\$101.75
2ZFTJB10X	Z-LOK 10IN X 22L BRANCH	\$106.58



**Adaptor for Flexible Stainless  
Steel Round Category I  
Chimney Liner**

**Stove Adapter Only**

Dia	Part ID	Each
3"	2CNNS03	\$50.98
4"	2CNNS04	\$53.66
5"	2CNNS05	\$56.49
5.5"	2CNNS05.5	\$59.44
6"	2CNNS06	\$59.44
7"	2CNNS07	\$62.57
8"	2CNNS08	\$65.75

**Order No: (dia)** 2CNNS\_\_ (deg dia)



Stove Adaptor

**Swivel Offset Flex Ready Adaptor**

No Handle - No Tabs

Dia	Part ID	Description	Each
3"	2ZOA4503A	Swivel flex adaptor 3 in - 45 deg adj	\$43.65
4"	2ZOA4504A	Swivel flex adaptor 4 in - 45 deg adj	\$45.84
5.5"	2ZOA450605.5A	Swivel flex adaptor 5.5 in - 45 deg adj	\$76.35
6"	2ZOA4506A	Swivel flex adaptor 6 in - 45 deg adj	\$76.35
3"	2ZOA9003A	Swivel flex adaptor 3 in - 90 deg adj	\$51.36
4"	2ZOA9004A	Swivel flex adaptor 4 in - 90 deg adj	\$53.93
6"	2ZOA9006A	Swivel flex adaptor 6 in - 90 deg adj	\$105.60

**Order No: (dia)** 2ZDOA\_\_\_\_ (deg dia)

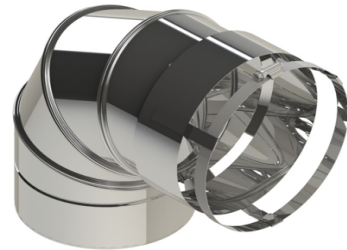



## Flexible Stainless Steel Round Liner Category I Chimney Liner Offset Insert Adapter

### Offset Adaptor

Dia	Part ID	Description	Each
6"	2ZR24AIB06	SS ADJUSTABLE INSERT BOOT 6 IN	\$287.55
8"	2ZR24AIB08	SS ADJUSTABLE INSERT BOOT 8 IN	\$399.79

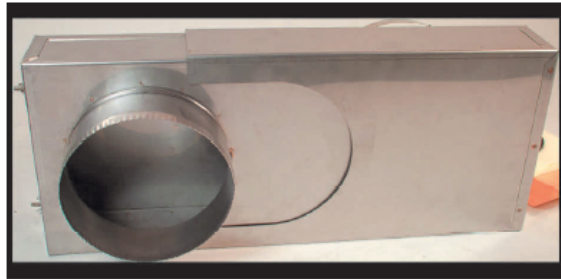
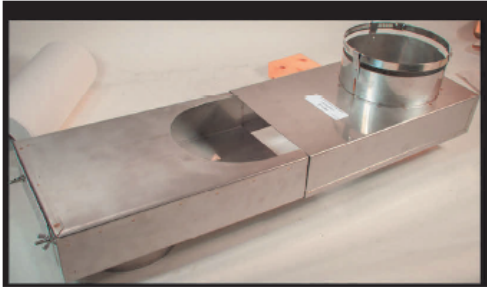
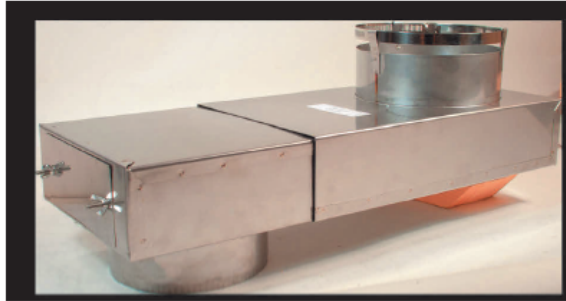
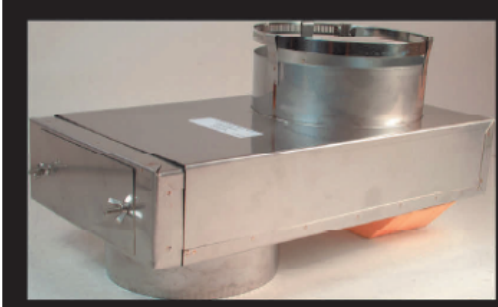

**304 Stainless Steel Rigid Liner**

Fusion welded pipe seam for smoother finish and better fit.

Dia.	Lgth.	Part ID	Each
5"	1 FT	2ZR321F0501	\$42.41
6"	1 FT	2ZR321F0601	\$46.01
7"	1 FT	2ZR321F0701	\$51.46
8"	1 FT	2ZR321F0801	\$74.81
9"	1 FT	2ZR321F0901	\$85.01
10"	1 FT	2ZR321F1001	\$99.07
5"	2 FT	2ZR321F0502	\$72.23
6"	2 FT	2ZR321F0602	\$77.62
7"	2 FT	2ZR321F0702	\$87.18
8"	2 FT	2ZR321F0802	\$96.85
9"	2 FT	2ZR321F0902	\$99.34
10"	2 FT	2ZR321F1002	\$106.58
5"	3 FT	2ZR321F0503	\$94.99
6"	3 FT	2ZR321F0603	\$108.39
7"	3 FT	2ZR321F0703	\$122.52
8"	3 FT	2ZR321F0803	\$136.21
9"	3 FT	2ZR321F0903	\$145.29
10"	3 FT	2ZR321F1003	\$149.13
5"	4 FT	2ZR321F0504	\$118.52
6"	4 FT	2ZR321F0604	\$135.69
7"	4 FT	2ZR321F0704	\$150.02
8"	4 FT	2ZR321F0804	\$171.45
9"	4 FT	2ZR321F0904	\$178.34
10"	4 FT	2ZR321F1004	\$192.76

Order No: 2ZR321F \_ \_ \_ \_ (dia/lgth)



**Fixed Stainless Steel 45° Elbow**

Dia.		Part ID	Each
5"	45° Elbow	2RE45XX05	\$41.64
6"	45° Elbow	2RE45XX06	\$46.45
7"	45° Elbow	2RE45XX07	\$48.33
8"	45° Elbow	2RE45XX08	\$55.74
9"	45° Elbow	2RE45XX09	\$64.68
10"	45° Elbow	2RE45XX10	\$69.31

Order No: 2RE45XX \_ \_ (dia)



**Fixed Stainless Steel 90° Elbow**

Dia.		Part ID	Each
5"	90° Elbow	2RE90XX05	\$56.42
6"	90° Elbow	2RE90XX06	\$66.19
7"	90° Elbow	2RE90XX07	\$85.84
8"	90° Elbow	2RE90XX08	\$103.02
9"	90° Elbow	2RE90XX09	\$114.52
10"	90° Elbow	2RE90XX10	\$122.63

Order No: 2RE90XX \_ \_ (dia)



**Stainless Steel Rigid Stacking Tee with Cap and removable Long Spout**

**Note:** This style tee is to be used with Z-Flex rigid liner or when stacking two tees together.

Refer to flex ready tee for use with Z-Flex flexible liner.

**Note:** 3" and 10" nose spouts are not removable.

Dia.		Part ID	Each
3"	SS Tee	2ZRB TXX03	\$100.63
4"	SS Tee	2ZRB TXX04	\$110.33
5"	SS Tee	2ZRB TXX05	\$120.10
6"	SS Tee	2ZRB TXX06	\$134.35
7"	SS Tee	2ZRB TXX07	\$143.12
8"	SS Tee	2ZRB TXX08	\$154.88
9"	SS Tee	2ZRB TXX09	\$181.88
10"	SS Tee	2ZRB TXX10	\$208.89

Order No: 2ZRB TXX \_ \_ (dia)



**Stainless Steel Increaser**

Diameters	Part ID	Each
3" to 4" Increaser	2IN314X	\$55.39
4" to 5" Increaser	2IN415X	\$65.68
5" to 6" Increaser	2IN516X	\$75.93
6" to 7" Increaser	2IN617X	\$86.17
6" to 8" Increaser	2IN618X	\$96.43
7" to 8" Increaser	2IN718X	\$106.70
8" to 10" Increaser	2IN8110X	\$116.96

Order No: 2IN \_ I \_ (sm) (lg)



Used to increase the liner size to accommodate a range of flue sizes, appliances and installations

**Stainless Steel Reducer**

Diameters	Part ID	Each
4" to 3" Reducer	2RD4R3X	\$55.39
5" to 4" Reducer	2RD5R4X	\$65.68
6" to 5" Reducer	2RD6R5X	\$75.93
7" to 6" Reducer	2RD7R6X	\$86.17
8" to 6" Reducer	2RD8R6X	\$96.43
8" to 7" Reducer	2RD8R7X	\$106.70
10" to 8" Reducer	2RD10R8X	\$116.96

Order No: 2RD \_ R \_ (lg) (sm)

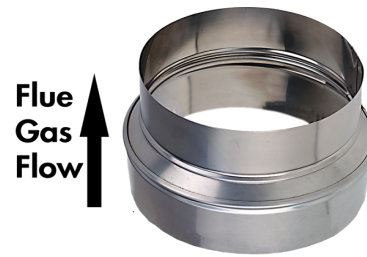

Used to decrease the liner size to accommodate a range of flue sizes, appliances and

**Stainless Steel Deluxe Rain Cap**

The deluxe rain cap prevents deterioration caused by moisture entering the chimney.  
(Storm collar is included).

Diameter	Part ID	Each
3"	2RNCAPS03	\$106.27
4"	2RNCAPS04	\$119.12
5"	2RNCAPS05	\$131.81
5.5"	2RNCAPS05.5	\$139.45
6"	2RNCAPS06	\$144.65
7"	2RNCAPS07	\$157.56
8"	2RNCAPS08	\$169.72
9"	2RNCAPS09	\$179.05
10"	2RNCAPS10	\$190.53

Order No: 2RNCAPS \_ \_ (dia)



**Nose Cone\***

Diameter	Part ID	Each
3"	2NCXXX03	\$81.49
4"	2NCXXX04	\$83.96
5"	2NCXXX05	\$86.49
5.5"	2NCXXX05.5	\$87.70
6"	2NCXXX06	\$88.94
7"	2NCXXX07	\$140.37
8"	2NCXXX08	\$144.22
10"	2NCXXX10	\$154.64

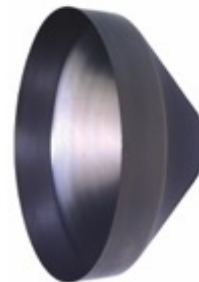

\*Nose cone used to snake flexible chimney liner down chimney flue. Tapered design self centers liner for smoother installation.



# Flexible Direct Vent

For Natural Gas  
and Propane

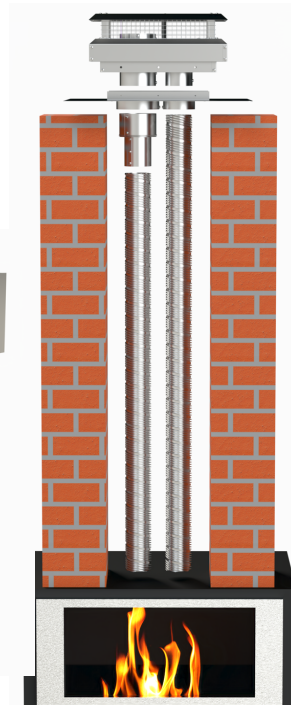

**DVI Kits**

Designed for use when converting existing wood-burning fireplace into gas fired.  
Allows for completely sealed system that does not compromise indoor air quality.  
Kit includes 2 Triple Lock<sup>®</sup> Gas Liners, one for flue exhaust, the other for outside combustion air.  
Includes either extreme weather or decorative co-linear termination options.

FLUE Dia	INTAKE Dia	Order No: Part ID	Description	LIST Each
3	3	2DVI335D	DV Co-Linear 3/3 Decorative Kit x 35ft	\$990.09
3	3	2DVI335LP	DV Co-Linear 3/3 Low Profile Termination Kit x 35ft	\$1,155.00
3	3	2DVI335X	DV Co-Linear 3/3 Extreme Weather Kit x 35ft	\$827.78
4	3	2DVI435D	DV Co-Linear 4/3 Decorative Kit x 35ft	\$990.09
4	3	2DVI435LP	DV Co-Linear 4/3 Low Profile Termination Kit x 35ft	\$1,155.00
4	3	2DVI435X	DV Co-Linear 4/3 Extreme Weather Kit x 35ft	\$827.78

**Kit includes:**

Chimney Liners (Exhaust and Intake)  
Extreme Weather Cap/Flashing OR Decorative Cap/Flashing  
Self Tapping Screws.

**Extreme Weather Kit**



**Decorative Kit**



**Low Profile Kit**

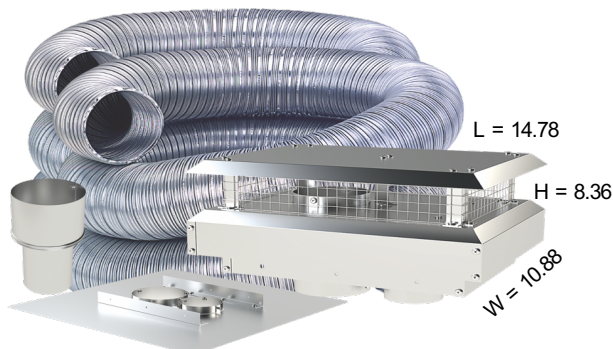

**Direct Vent Kit Vertical Extreme Weather Termination**

SIZE	ORDER #	LIST PRICE
4" x 7"	2DVK40705VX	\$1,301.10
4" x 7"	2DVK40710VX	\$1,457.85
4" x 7"	2DVK40720VX	\$1,645.05
4" x 7"	2DVK40740VX	\$2,083.80
5" x 8"	2DVK50805VX	\$1,712.40
5" x 8"	2DVK50810VX	\$1,816.65
5" x 8"	2DVK50820VX	\$2,018.25
5" x 8"	2DVK50840VX	\$2,476.28

Kit includes: Vertical Extreme Weather Termination, Coaxial Flexible Vent, Spacers, Supports, Fire Stop/Insulation Shield & Insulation Collar, Rigid Pipe with Roof Support, 0° to 30° Roof Flashing, Storm Collar/Support and Screws.

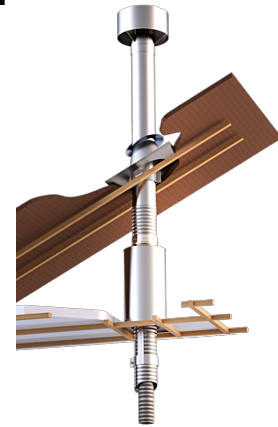

**Direct Vent Kit Horizontal ROUND Termination**

SIZE	ORDER #	LIST PRICE
4" x 7"	2DVK40705HR	\$423.60
4" x 7"	2DVK40710HR	\$579.38
4" x 7"	2DVK40720HR	\$779.55
4" x 7"	2DVK40740HR	\$1,270.20
5" x 8"	2DVK50805HR	\$537.00
5" x 8"	2DVK50810HR	\$654.60
5" x 8"	2DVK50820HR	\$869.78
5" x 8"	2DVK50840HR	\$1,383.52

Kit includes: Horizontal ROUND Termination, Coaxial Flexible Vent, Spacers, Supports and Screws

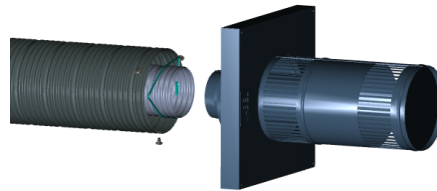

**Direct Vent Kit Horizontal SQUARE Termination**

SIZE	ORDER #	LIST PRICE
4" x 7"	2DVK40705HT	\$423.60
4" x 7"	2DVK40710HT	\$579.38
4" x 7"	2DVK40720HT	\$779.55
4" x 7"	2DVK40740HT	\$1,270.20
5" x 8"	2DVK50805HT	\$537.00
5" x 8"	2DVK50810HT	\$654.60
5" x 8"	2DVK50820HT	\$869.78
5" x 8"	2DVK50840HT	\$1,383.52

Kit includes: Horizontal SQUARE Termination, Coaxial Flexible Vent, Spacers, Supports and Screws

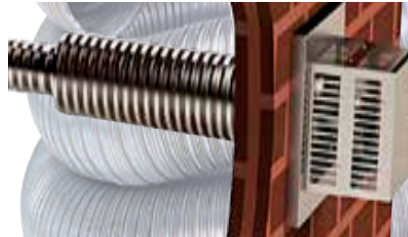

**Coaxial Flexible Extension Kit**

SIZE	ORDER #	LIST PRICE
4" x 7"	2DVK40720X	\$765.23
5" x 8"	2DVK50820X	\$803.32

Kit includes: Coaxial Flexible Coupling, 20' Coaxial Flexible Vent, Spacers, Supports, Sealant and Screws.

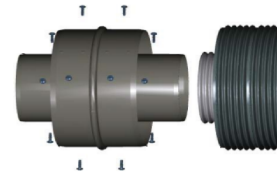

**Coaxial Flexible Coupling Kit**

SIZE	ORDER #	LIST PRICE	A	B
4" x 7"	2DVK407C	\$159.53	3.95	7
5" x 8"	2DVK508C	\$168.22	4.95	8

Kit includes: Coaxial Flexible Coupling, Sealant and Screws.

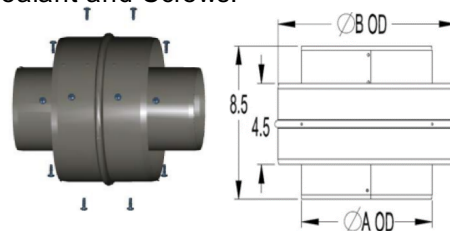

**Coaxial Flexible Spacer Kit (10/Kit)**

SIZE	ORDER #	LIST PRICE	A	B
4" x 7"	2DVK47S	\$59.25	4	7
5" x 8"	2DVK58S	\$60.75	5	8

Kit includes: 10 Coaxial Spacers

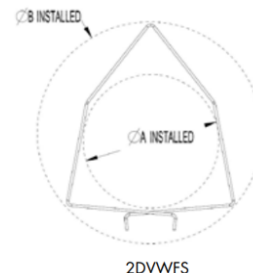



**Adaptor DV 4/6.625 to Flex 4/7 Kit**

SIZE	ORDER #	LIST PRICE
4" x 7"	2DVK407A	\$156.38

Kit includes: Adaptor, Sealant & Screws.

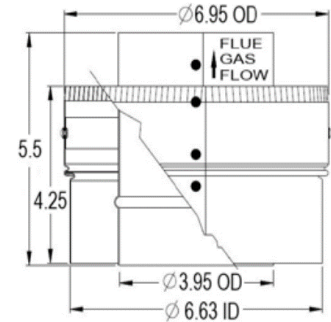

**Adaptor DV 5/8 to Flex 5/8 Kit**

SIZE	ORDER #	LIST PRICE
5" x 8"	2DVK508A	\$160.43

Kit includes: Adaptor, Sealant & Screws.

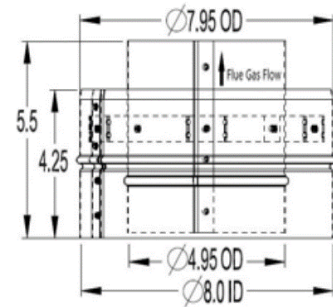

**Coaxial Flexible Support Kit (5/Kit)**

SIZE	ORDER #	LIST PRICE	A
4" x 7"	2DVK07SUP	\$103.65	7.5
5" x 8"	2DVK08SUP	\$106.27	8.5

Kit includes: 5 Coaxial Flexible Supports.

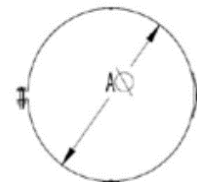

**4"-7" Thick Wall Thimble**

SIZE	ORDER #	LIST PRICE	A	B	C
4" x 7"	2DVK07WT	\$124.12	7.75	10.5	13
5" x 8"	2DVK08WT	\$121.20	8.75	11.5	14

Kit includes: 4"-7" Thick Wall Thimble.

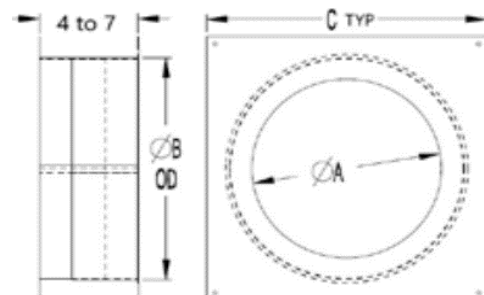

**6"-11" Thick Wall Thimble Extended**

SIZE	ORDER #	LIST PRICE	A	B	C
4" x 7"	2DVK07WTE	\$127.05	7.75	10.5	13
5" x 8"	2DVK08WTE	\$143.18	8.75	11.5	14

Kit includes: 6"-11" Thick Wall Thimble.

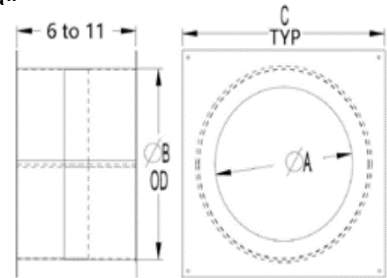

**Siding Standoff**

SIZE	ORDER #	LIST PRICE	A	B	C
4" x 7"	2DVK07SS	\$102.74	7.75	14	15
5" x 8"	2DVK08SS	\$110.12	8.75	15	16

Kit includes: Siding Standoff.

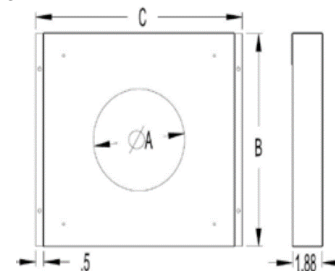

**Fire Stop**

SIZE	ORDER #	LIST PRICE	A	B	C
4" x 7"	2DVK07FS	\$86.70	7.5	10.5	13
5" x 8"	2DVK08FS	\$92.93	8.5	11.5	14

Kit includes: Fire Stop.

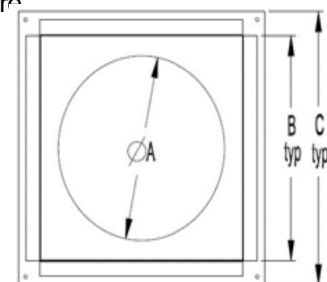

**Fire Stop/Insulation Shield & Insulation Collar Kit**

SIZE	ORDER #	LIST PRICE	A	B	C	A (Collar)	B (Collar)
4" x 7"	2DVK07FSIS	\$259.95	7.75	10.5	13	7.25	10.75
5" x 8"	2DVK08FSIS	\$268.35	8.75	11.5	14	8.25	11.75

Kit includes: Fire Stop/Insulation Shield & Insulation Collar.

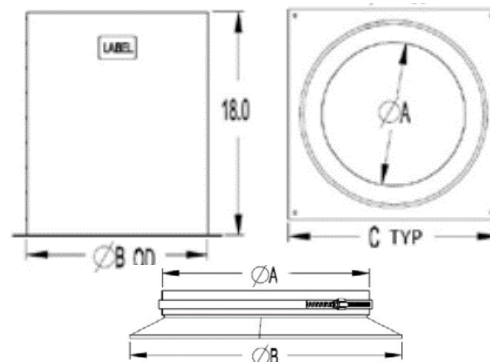

**Flashing 30 to 45 Degree Pitched Roofs**

SIZE	ORDER #	LIST PRICE	A	B	C
4" x 7"	2DVK07F	\$303.60	7.25	11.8	20
5" x 8"	2DVK08F	\$303.60	8.25	12.8	21

Kit includes: 30° to 45° Pitched Roof Flashing.

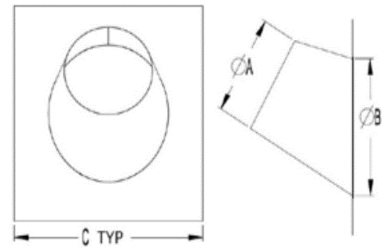

**Rigid Extension Pipe Kit**

SIZE	ORDER #	LIST PRICE	A
4" x 7"	2DVKRE47	\$336.22	6.95
5" x 8"	2DVKRE58	\$381.30	7.95

Kit includes: 30" Long Rigid Outer & Flex Inner Pipe with Male Connector, Guy Band, Sealant & Screws.

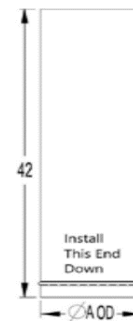

**Sealant**

ORDER #	LIST PRICE
2DVKS	\$54.82

Kit includes: Sealant.

## Z-FLEX US®, INC Aluminum Chimney Liner Limited Twenty-Five Year Warranty

Z-Flex® (U.S.), Inc. ("seller") extends the following LIMITED WARRANTY on its aluminum chimney liners (the "Liners") to the original end-user of the Liner:

Seller warrants the Liners against all defects in workmanship and material for a period of twenty-five (25) years from the date of installation. This warranty shall apply only when the Liner has been installed according to UL and equipment manufacturer's installation instructions. Deviating from the installation and use instructions included with the Liner will void the warranty.

Under this Limited Warranty, Seller's sole responsibility and liability shall be to replace the Liner and/or accessories, if found by Seller to be defective, without charge to the end-user, and shall not include replacement installation or other costs. Seller shall not be responsible or liable for other expenses or damages, whether direct, incidental or consequential, to other areas of the property in which the Liner is installed, to the surrounding property or to any persons.

**IMPORTANT:** The Liners are designed for use with the following fuels only: natural gas and propane gas. No other fuels should be used with the Liner. Use of any fuel other than those recommended by Seller for use with its Liners will void the warranty. Excessive condensation with high chlorine content may corrode aluminum. Where these conditions prevail, Seller recommends AL29-4C® Stainless Steel Liners. Refer to equipment manufacturer's installation instructions for proper chimney liner material for appliances which produce condensation.

**WARNING: THE LINER SYSTEM MUST BE INSPECTED ANNUALLY BY A QUALIFIED CHIMNEY TECHNICIAN. SULPHUR RESIDUE, CONDENSATION WITH HIGH CHLORINE CONTENT, OR THE USE OF UNAPPROVED CHEMICAL CLEANERS MAY WARP OR CORRODE THE LINER, WHICH MAY RESULT IN THE FAILURE OF THE LINER SYSTEM. FAILURE OF THE LINER SYSTEM MAY RESULT IN THE LEAKAGE OF HARMFUL CARBON MONOXIDE GASES CAUSING DEATH OR SERIOUS ILLNESS. IN THE EVENT OF A CHIMNEY FIRE, THE LINER SYSTEM SHOULD NOT BE USED UNTIL IT HAS BEEN**

INSPECTED FOR DAMAGE OR FAILURE BY A QUALIFIED CHIMNEY TECHNICIAN. Such misuse of the Liner will void the warranty.

To activate the warranty, the end-user must complete and return the Z-Flex® Warranty Registration Card within ninety (90) days of installation of the Liner. Upon receipt of written notice of any defect, Z-Flex® reserves the right to examine or engage others to examine the Liner. Such examination must establish reasonable proof of defective material or workmanship justifying replacement.

**NO OTHER EXPRESS WARRANTY HAS BEEN MADE OR WILL BE MADE ON BEHALF OF SELLER WITH RESPECT TO THE LINERS OR THE INSTALLATION OR REPLACEMENT OF THE LINERS. SELLER SHALL NOT BE RESPONSIBLE FOR ANY OTHER DAMAGE, LOSS OF USE OF THE PREMISES, INCONVENIENCE OR LOSS OR DAMAGE TO PERSONAL PROPERTY, WHETHER DIRECT OR INDIRECT, AND WHETHER ARISING IN CONTRACT OR TORT.**

As some states do not allow the exclusion or limitation of incidental or consequential damages, the above limitations or exclusions may not apply to you.

**IMPLIED WARRANTIES, INCLUDING ANY WARRANTY OF MERCHANTABILITY OR FITNESS FOR A PARTICULAR PURPOSE, IMPOSED ON THIS SALE UNDER STATE/PROVINCIAL LAW, ARE LIMITED TO THE PERIOD DURING WHICH THE ORIGINAL END-USER OWNS OR OCCUPIES THE PREMISES IN WHICH THE LINER IS INSTALLED. AS SOME STATES DO NOT ALLOW LIMITATIONS ON THE LENGTH OF AN IMPLIED WARRANTY, THE ABOVE LIMITATION MAY NOT APPLY TO YOU!**

Claims under this Warranty must be made within the warranty period in writing and directed to: in the USA; Warranty claims, Z-Flex® (US) Inc., 20 Commerce Park North, Bedford, New Hampshire 03110, (603)669-5136 or (800) 645-5600. In Canada: Warranty Claims, Z-Flex® Inc, 452 Attwell Drive, Etobicoke, Ontario M9W 5C3, (416)679-0045. This warranty gives you specific legal rights, and you may also have other rights that vary in different states/provinces.

## Z-FLEX® US, INC Stainless Steel Chimney Liner Limited Lifetime Warranty

Z-Flex® (U.S.), Inc. ("Seller") extends the following LIMITED WARRANTY on its stainless steel chimney liners (the "Liners"):

Seller warrants the Liners against all defects in workmanship and material for as long as the original end-user owns or occupies the premises in which the Liner is installed. This warranty shall apply only when the Liner has been installed according to UL and equipment manufacturer's installation instructions. Deviating from the installation and use instructions included with the Liner will void the warranty.

Under this Limited Warranty, Seller's sole responsibility and liability shall be to replace the Liner and/or accessories, if found by Seller to be defective, without charge to the end-user, and shall not include replacement installation or other costs. Seller shall not be responsible or liable for other expenses or damages, whether direct, incidental or consequential, to other areas of the property in which the Liner is installed, to the surrounding property or to any persons.

**IMPORTANT:** The Liners are designed for use with the following fuels only: natural gas, propane gas, non-recycled standard heating oil and seasoned hardwood. No other fuels should be used with the Liner, including coal, ocean driftwood or garbage. Use of any fuel other than those recommended by Seller for use with its Liners will void the warranty. Excessive condensation with high chlorine content will corrode some stainless steel. Where these conditions prevail, Seller recommends AL29-4C™ Stainless Steel Liners. Refer to equipment manufacturer's installation instructions for proper chimney liner material for appliances which produce condensation.

**WARNING: THE LINER SYSTEM MUST BE INSPECTED ANNUALLY BY A QUALIFIED CHIMNEY TECHNICIAN. CREOSOTE ACCUMULATION MAY CAUSE CHIMNEY FIRES WHICH MAY WARP OR DAMAGE THE CHIMNEY LINER. CONDENSATION WITH HIGH CHLORINE CONTENT, SULPHUR RESIDUE OR THE USE OF UNAPPROVED CHEMICAL CLEANERS MAY CAUSE CORROSION, WHICH MAY RESULT IN THE FAILURE OF THE LINER SYSTEM. FAILURE OF THE LINER SYSTEM MAY RESULT IN THE LEAKAGE OF HARMFUL CARBON MONOXIDE GASES CAUSING DEATH OR SERIOUS INJURY OR ILLNESS.**

IN THE EVENT OF A CHIMNEY FIRE, THE LINER SYSTEM SHOULD NOT BE USED UNTIL IT HAS BEEN INSPECTED FOR DAMAGE OR FAILURE BY A QUALIFIED CHIMNEY TECHNICIAN. Such misuse of the Liner will void the warranty.

To activate the warranty, the end-user must complete and return the Z-Flex® Warranty Registration Card within ninety (90) days of installation of the Liner. Upon receipt of written notice of any defect, Z-Flex® reserves the right to examine or engage others to examine the Liner. Such examination must establish reasonable proof of defective material or workmanship justifying replacement.

**NO OTHER EXPRESS WARRANTY HAS BEEN MADE OR WILL BE MADE ON BEHALF OF SELLER WITH RESPECT TO THE LINERS OR THE INSTALLATION OR REPLACEMENT OF THE LINERS. SELLER SHALL NOT BE RESPONSIBLE FOR ANY OTHER DAMAGE, LOSS OF USE OF THE PREMISES, INCONVENIENCE OR LOSS OR DAMAGE TO PERSONAL PROPERTY, WHETHER DIRECT OR INDIRECT, AND WHETHER ARISING IN CONTRACT OR TORT.**

As some states do not allow the exclusion or limitation of incidental or consequential damages, the above limitations or exclusions may not apply to you.

**IMPLIED WARRANTIES, INCLUDING ANY WARRANTY OF MERCHANTABILITY OR FITNESS FOR A PARTICULAR PURPOSE, IMPOSED ON THIS SALE UNDER STATE/PROVINCIAL LAW, ARE LIMITED TO THE PERIOD DURING WHICH THE ORIGINAL END-USER OWNS OR OCCUPIES THE PREMISES IN WHICH THE LINER IS INSTALLED. AS SOME STATES DO NOT ALLOW LIMITATIONS ON THE LENGTH OF AN IMPLIED WARRANTY, THE ABOVE LIMITATION MAY NOT APPLY TO YOU.**

Claims under this Warranty must be made within the warranty period in writing and directed to: in the USA; Warranty claims, Z-Flex® (US) Inc., 20 Commerce Park North, Bedford, New Hampshire 03110, (603)669-5136 or (800) 645-5600. In Canada: Warranty Claims, Z-Flex® Inc, 452 Attwell Drive, Etobicoke, Ontario M9W 5C3, (416)679-0045. This warranty gives you specific legal rights, and you may also have other rights that vary in different states/provinces.

## Z-FLEX® US, INC Special Gas Vent (Z-VENT AL29-4C®) Limited Fifteen Year Warranty

Z-Flex® ("Seller") extends the following LIMITED WARRANTY for Z-VENT for the ("Z-VENT"): Seller warrants that at the time of purchase, the Z-VENT will be free of manufacturer's defects in material and/or workmanship. This warranty is valid for a period of fifteen (15) years from the date of purchase, provided that the Z-VENT has been installed according to Z-Flex® installation instructions. Deviating from the installation and use instructions included with the Z-VENT will void the warranty.

Under this Limited Warranty, Seller's sole responsibility and liability shall be to replace the Z-VENT and/or accessories if found by Seller to be defective according to the terms of the warranty, and shall not include replacement installation or other costs.

**IMPORTANT:** The Z-VENT is designed for use with Category II, III, and IV furnace and boiler venting should not be used with any other type of furnace and boiler venting. Use of the Z-VENT with any other furnace and boiler venting other than those recommended by Seller for use with its Z-VENT will void the warranty.

**WARNING: CONDENSATION WITH HIGH ACID CONTENT MAY BE PRODUCED DUE TO UNFORESEEN CONDITIONS. YOUR HEATING APPLIANCE AND VENTING SYSTEM SHOULD BE INSPECTED BY A LICENSED CONTRACTOR ON AN ANNUAL BASIS FOR POSSIBLE SIGNS OF DETERIORATION DUE TO RUSTING OR PIN HOLES. CONDENSATION WITH HIGH ACID CONTENT MAY CAUSE LEAKAGE OF HARMFUL GASES WHICH CAN CAUSE NAUSEA, FAINTING OR DEATH, IF DETERIORATION IS DETECTED CEASE USE OF HEATING SYSTEM AND CALL FURNACE/BOILER INSTALLER FOR REMEDIAL ACTION.**

To activate this warranty, the end-user must complete and return the Z-Flex® Warranty Registration Card within ninety (90) days of installation of the Z-VENT. Upon written notice of any defects, Z-Flex® reserves the right to examine or establish reasonable proof of defective material or workmanship justifying replacement. **NO OTHER EXPRESS WARRANTY HAS BEEN MADE TO WILL BE MADE ON BEHALF OF SELLER WITH RESPECT TO THE Z-VENT OR THE INSTALLATION OR REPLACEMENT OF THE Z-VENT. SELLER SHALL NOT BE LIABLE FOR ANY SPECIAL, INCIDENTAL, INDIRECT OR CONSEQUENTIAL DAMAGES.**

As some jurisdictions do not allow the exclusion or limitation of incidental or consequential damages, the above limitations or exclusions may not apply to you.

**IMPLIED WARRANTIES, INCLUDING ANY WARRANTY OF MERCHANTABILITY OR FITNESS FOR A PARTICULAR PURPOSE, IMPOSED ON THIS SALE UNDER STATE/PROVINCIAL LAW, ARE LIMITED TO THE PERIOD DURING WHICH THIS WARRANTY IS IN EFFECT. AS SOME JURISDICTIONS DO NOT ALLOW LIMITATIONS ON THE LENGTH OF AN IMPLIED WARRANTY, THE ABOVE LIMITATION MAY NOT APPLY TO YOU.**

Claims under this warranty must be made within the warranty period in writing and directed to: in the USA; Warranty claims, Z-Flex® (US) Inc., 20 Commerce Park North, Bedford, New Hampshire 03110, (603)669-5136 or (800) 645-5600. In Canada: Warranty Claims, Z-Flex® Inc, 452 Attwell Drive, Etobicoke, Ontario M9W 5C3, (416)679-0045. This Warranty gives your specific legal rights and you may have other rights that vary in different states/provinces.

## General Terms and Conditions

1. All prices are FOB point of shipment. Terms are NET 30. Minimum \$250.00 per order. Seller reserves the right to revoke extended credit to buyer because of failure to pay or any other reason deemed sufficient to seller.
2. The routing of a shipment is at the seller's option and will be prepaid and invoiced to the purchaser unless otherwise specified. A \$5.00 handling charge will be added to all UPS shipments. The seller shall have no liability for damage in transit.
3. Claims for corrections or deductions from invoices must be made within thirty (30) days.
4. Returns will not be accepted.
5. Sellers prices do not include sales, use, excise or similar taxes. The buyer shall be responsible for any present or future sales, excise or similar tax applicable to the sale or use of the products.
6. For a period of one month from date of shipment the seller will repair or replace goods which fail due to

manufacturing defects, provided the goods are used as recommended by the seller.

7. All purchase orders accepted by the seller are considered firm commitments and are not subject to cancellation except upon terms acceptable to seller which will protect seller from loss.
8. The seller shall not be liable for any failure of delay in delivery due to any cause beyond its control.
9. The seller reserves the right to make minor changes to product without notice. All products should be tested in actual working environments. Information given is only a guide. Variables present in given applications make firm recommendations impossible. Adequate testing in actual service conditions must be carried out in order to establish definite suitability for end use.
10. The terms and conditions stated herein shall be binding and not modified unless agreed to in writing by a duly authorized representative of the seller.

**Prices subject to change without prior notice – F.O.B. WAREHOUSE February 2024**

The items described in this document and other documents provided by NovaFlex Hose Inc., NovaFlex Industries Inc., Z-Flex U.S. Inc., their subsidiaries and their authorized representatives (“Seller”) are available for sale at prices established by Seller. An order from any customer (“Buyer”) shall be governed by all of the following terms and conditions of sale (“Terms and Conditions”). Upon Seller’s acceptance of Buyer’s purchase order the Terms and Conditions from part of the agreement between Buyer and Seller. All goods available for sale are referred to as “Products”. The Terms and Conditions are also available on our website at [www.novaflex.com](http://www.novaflex.com).

**1. Prices; Price Adjustments; Payments.** Prices stated in this document are valid for 30 days. Minimum purchase per order per location is \$250. After 30 days, Seller may change prices to reflect any increase in its costs resulting from state, provincial, federal or local legislation, price increases from its suppliers, or any change in the rate, charge, or classification of any carrier. The prices in this document do not include any sales, use, or other taxes unless so stated. Buyer shall be responsible for any present or future sales, exercise or similar tax applicable to the sale or use of the Products. Unless otherwise specified by Seller, all prices are F.O.B. Seller’s facility, and payment is due 30 days from the date of invoice. After 30 days, Buyer shall pay interest on any unpaid invoices at the rate of 1.5% per month.

**2. Delivery Dates; Title and Risk; Shipment.** All delivery dates are approximate and Seller shall not be responsible for any damages resulting from any delay due to a cause beyond its control. Regardless of manner of shipment, title to any Products and risk of loss or damage shall pass to Buyer upon tender to the carrier at Seller’s facility. Unless otherwise stated, Seller may exercise its judgment in choosing the carrier and means of delivery. At Seller’s option carrier charges shall be prepaid and invoiced to Buyer. A \$5.00 handling charge will be added to all UPS shipments. No deferment of shipment at Buyers’ request beyond the respective dates indicated will be made except on terms that will indemnify and hold Seller harmless against all loss and additional expense. Buyer shall be responsible for any additional shipping charges incurred by Seller due to Buyer’s changes in shipping or product specifications.

**3. Buyer Responsibility and Acceptances.** Buyer, and user, if different, through their own analysis and testing are solely responsible for making the final selection of Products and assuring that all performance, endurance, maintenance, safety and warning requirements are met. User must analyze all aspects of the application in the field and follow applicable industry standards and Product information. Adequate testing in actual service conditions must be carried out by Buyer and/or user to establish definite suitability for end use. If Seller suggests Products for an application based on data, drawings, designs, diagrams, specifications or other communications (“Information”) provided by Buyer or user, then Buyer and user are responsible for determining that the Information is suitable for use of the Product in the application. Submission of an order for production quantities of a Product following receipt of a final version of a prototype is (a) Buyer’s acceptance of the prototype as meeting all of Buyer’s requirements as set out in the Information supplied by Buyer and, (b) Buyer’s acceptance of the Products based on the prototype, provided the Products are manufactured within Seller’s standard tolerances.

**4. Returns, Cancellations and Changes.** Returns shall not be accepted. Orders shall not be subject to cancellation or change by Buyer for any

reason, except with Seller’s written consent on terms which protect Seller from any loss. Seller may change product features, specifications, designs and availability with notice to Buyer.

**5. Claims.** Buyer shall promptly inspect all Products upon delivery. No claims for corrections or deductions from invoices will be allowed unless reported to Seller within 7 days of delivery.

**6. Contingencies.** Seller shall not be liable for any default or delay in performance if caused by circumstances beyond the reasonable control of Seller.

**7. Warranty.** Seller warrants that the Products sold hereunder shall be free from defects in material or workmanship for a period of twelve months from the date of delivery to Buyer. This warranty is made only to Buyer and does not extend to anyone to whom Products are sold after purchased from Seller. The prices charged for Seller’s products are based upon the exclusive limited warranty stated above, and upon the following disclaimer: **DISCLAIMER OF WARRANTY: This warranty comprises the sole and entire warranty pertaining to Products. Seller disclaims all other warranties, express and implied, including merchantability and fitness for a particular purpose.**

**8. Limitation of Liability.** For a period of 30 days from delivery Seller will, upon notification, at its option, repair or replace a defective product, or refund the purchase price. **In no event shall Seller be liable to Buyer for any special, indirect, incidental or consequential damages arising out of, or as the result of, the sale, delivery, non-delivery, servicing, use or loss of use of the Products or any part thereof, or for any charges or expenses of any nature incurred without Seller’s written consent, even if Seller has been negligent, whether in contract, tort or other legal theory. In no event shall Seller’s liability under any claim made by Buyer exceed the purchase price of the Products.**

**9. Improper Use and Indemnity.** Buyer shall indemnify, defend, and hold Seller harmless from any claim, liability, damages, lawsuits, and costs (including lawyer’s fees), whether for personal injury, property damage, patent, trademark or copyright infringement or any other claim, brought by or incurred by Buyer, Buyer’s employees, or any other person, arising out of: (a) improper selection, improper application or other misuse of Products purchased by Buyer; (b) any act or omission, negligent or otherwise, of Buyer; (c) Seller’s use of Information furnished by Buyer to manufacture Products; or (d) Buyer’s failure to comply with the Terms and Conditions. Seller will not indemnify Buyer under any circumstances except as otherwise provided.

**10. Limitation on Assignment.** Buyer may not assign its rights or obligations under this agreement without the prior written consent of Seller.

**11. Entire Agreement.** This agreement contains the entire agreement between the Buyer and Seller with respect to the subject matter of this agreement and supersedes all prior agreements, understandings, negotiations and discussions whether written or not.

**12. Waiver.** Failure to enforce any provision of this agreement will not waive the provision nor prejudice Seller’s right to enforce the provision in the future.

**13. Governing Law.** This agreement shall be governed by and construed in accordance with the laws of the State of New Hampshire.



# The Flexible Venting Solutions Specialist

Z-FLEX®, part of the Novaflex Group of companies, is the leading manufacturer of specialty venting systems for furnaces, boilers, water heaters, oil heaters, fireplaces, and more.

Z-FLEX® has been providing flexible answers to gas oil, pellet and wood venting applications since 1979. We have pioneered flexible chimney liner solutions and special gas vent (AL 29-4C®).\*

Constant innovations in materials and construction create products that deliver:

- Superior performance and increased efficiency
- Easier handling and faster, simpler installation
- Greater reliability, safety and increased service life

To that, we add responsive customer service and expert technical support.

The Novaflex Group® is a privately held company committed to continuous advancement in venting solutions. Novaflex® has one of the broadest product ranges available in the marketplace for the HVAC, industrial venting and hose industries. Throughout a more than forty year history, Novaflex® has earned a solid reputation for providing innovative and high quality products.

AL 29-4C® is a registered trademark of ATI Properties, Inc.



## U.S.A.

20 Commerce Park North  
Bedford, New Hampshire 03110-6911  
tel: 603.669.5136 fax: 888.889.3539

## CANADA

452 Attwell Drive  
Etobicoke, ON M9W 5C3  
tel: 416.679.0045 fax: 416.679.0051