

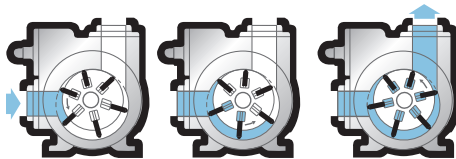

LGL3021

Multi-Purpose LPG Pump for Bulk Plants & Terminals



How Blackmer's sliding vane action works

Multi-Purpose LPG Transfer Pump

Based on Blackmer's industry standard LGLD3 transfer pump, the LGL3021 replaces competitive pumps without changing piping connections or motor drives. Whether filling an LPG bobtail or transport – the LGL3021 can do it faster and more efficiently than competitive models.

Applications

- Bulk plant service
- Multiple Cylinder filling
- Vaporizers
- Bobtail and transport loading & off-loading
- U.L. listed for use on propane, butane, butane/propane mixes and anhydrous ammonia

Features

- Designed for high differential pressure of 150 psi (10.34 bar)
- Sliding vane, positive displacement design for consistent performance
- Designed to bolt in place of competitive pumps without changing piping or motor drives
- Same performance and internal parts as LGLD3 pumps
- Cavitation suppression liner
- Replaceable liner and discs
- Ductile iron construction
- Factory ISO-9001 certified

Pump Specifications

Pump Model	Maximum Speed	GPM (L/min)	HP (kW)	Maximum Differential Pressure	Recommended Bypass Valve Setting	Relief Valve Setting	Maximum Working Pressure
LGL3021	800 rpm	112 (424)*	12.1 (9.0)	150 psi (10.34 bar)	125 psi (8.6 bar)	150 psi (10.34 bar)	350 psi (24.13 bar)

* Approximate delivery of propane at 640 rpm at 100 psi (6.89 bar) differential pressure.

Dimensions

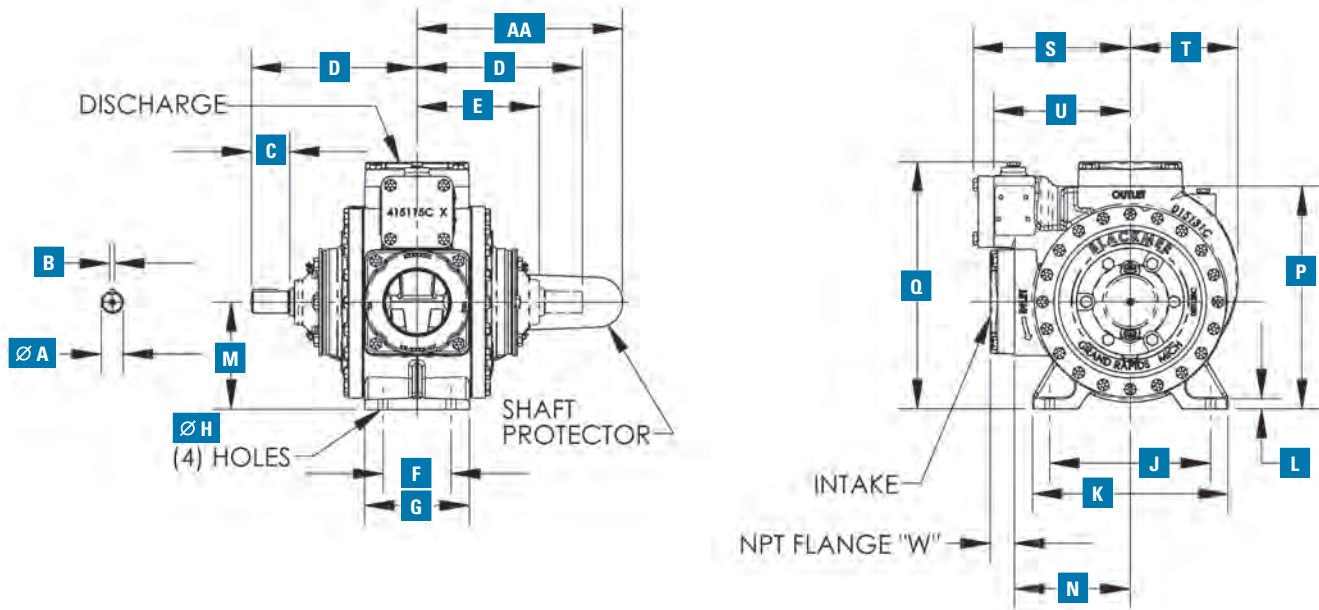

Model	Units	A	B	C	D	E	F	G	H	J	K	Pump Weight
LGL3021	in.	1 ¹ / ₈	1 ¹ / ₄	2	8 ¹ / ₂	6 ⁵ / ₁₆	3 ¹ / ₂	5 ³ / ₈	1 ¹ / ₂	8 ¹ / ₄	10	150 lbs.
	mm	-	-	50.8	215.9	160.3	88.9	136.5	12.7	203.2	254	68 kg
		L	M	N	P	Q	S	T	U	W	AA	Weight With STD Flanges
	in.	1 ¹ / ₂	5 ¹ / ₂	5 ¹⁵ / ₁₆	11 ⁷ / ₁₆	12 ¹¹ / ₁₆	7 ¹⁵ / ₁₆	5 ¹ / ₂	7	1 ¹ / ₄	10 ⁹ / ₁₆	157 lbs.
	mm	12.7	139.7	150.8	290.5	322.3	201.6	139.7	177.8	31.7	268.3	71 kg

Available Flanges

Model	Size
LGL3021	3" NPT Flange, Nodular
	4" NPT Flange, Nodular



Process | Energy | Military & Marine

World Headquarters

1809 Century Avenue SW, Grand Rapids, MI 49503-1530 USA
T 616.241.1611 F 616.241.3752 www.blackmer.com



Distributed By:

Printed in USA

© 2012 Blackmer

*Limited Warranty, contact your distributor or Blackmer for details.